

## Revolution and Stroke Counters Type 125 with Button Reset



- 4 or 5-digit display
- With button reset
- Miniature size
- Protection class IP 50

### TECHNICAL DATA

Display	4 or 5-digit, depending on version
Digit height	4 mm
Base plate	burnished sheet steel
Case	plastic, (PPO), glassfibre-reinforced, black
Cover	plastic (ASB) grey, (on request also available in black)
Weight	approx. 50 g
Counting mode	revolution counter: + (-), stroke counter: +
Transmission ratio	1:1 or 1:10, depending on version
Max. speed	1.500 rpm, with transmission 1:10 500 rpm (revolution counter only)
Switching distance	min. 18° (only stroke counter)
Max. stroke rate	500 strokes/min (stroke counter only)
Reset	manual reset with button
⚠	Don't push the reset pushbutton during the process

### DIMENSIONS

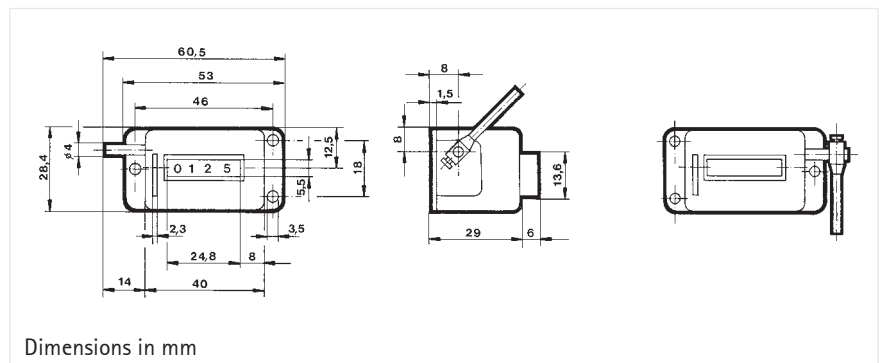

### ORDER INFORMATION

Revolution counter

Stroke counter

Actuation	Sense of rotation	4-digit, transmission ratio		5-digit, transmission ratio	
		1:1	1:10	1:1	1:10
	Bz	0 125 101	0 125 111	0 125 105	0 125 115
	Bw	0 125 102	0 125 112	0 125 106	0 125 116
	Bz	0 125 103	0 125 113	-	-
	Bw	0 125 104	0 125 114	0 125 108	0 125 118
	Bz	0 125 301	-	0 125 305	-
	Bw	0 125 302	-	0 125 306	-
	Bz	0 125 303	-	0 125 307	-
	Bw	0 125 304	-	0 125 308	-

Stroke lever Ordering code 0 600 026 Other stroke levers available on request