

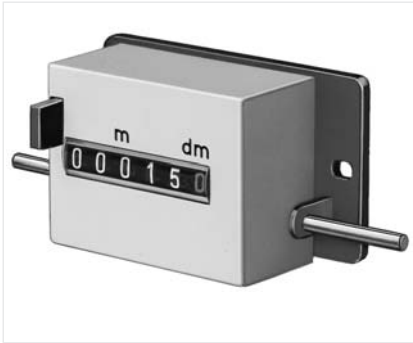

Revolution, Length, Stroke Counters Type 150



- Approved for calibration applications by the PTB (German Federal Institute for Physics and Technology)
- With button reset
- 6-digit display
- Protection class IP 50

TECHNICAL DATA





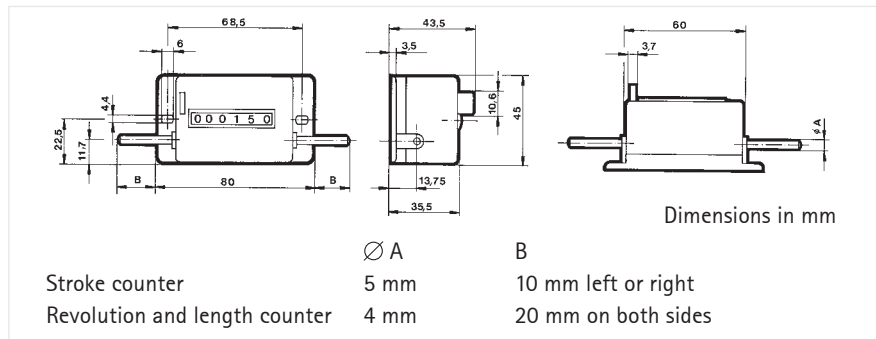



Display	6-digit
Digit height	4 mm
Case	plastic, (PA), glassfibre-reinforced, black
Cover	plastic (ASB), grey
Weight	approx. 70 g
Counting mode	+ (-), stroke counter: +
Transmission ratio	1:1, 1:2 or 1:10, depending on version
Max. speed	revolution counter: 3000 rpm, length counter 1500 rpm
Max. stroke rate	500 strokes/min (stroke counter only)
Torque	approx. 0.2 Ncm, stroke counter: approx. 5 Ncm
Actuating travel	min. 37° max. 43° (stroke counter only)
Reset	- with button, tactile touch 12 N - key reset available on request
	Don't push the reset pushbutton during the process

DIMENSIONS



ORDER INFORMATION

Revolution counter
Length counter
Stroke counter

Actuation	Sense of rotation	Indication	Unit	Transm. ratio 1:1 Ordering code	Transm. ratio 1:2 Ordering code	Transm. ratio 1:10 Ordering code
	Bz	999 999		-	-	0 150 103
	Bw	999 999		-	-	0 150 104
	Bz	99 999.9	m/dm	-	0 150 201	-
	Bw	99 999.9	m/dm	-	0 150 202	-
	Bz	999 999		0 150 301	-	-
	Bw	999 999		0 150 302	-	-
	Bz	999 999		0 150 303	-	-
	Bw	999 999		0 150 304	-	-

Stroke lever 0 600 003 For further stroke levers see accessories
Protective cover Ordering code 2 150 056*

* on request
For measuring wheels see accessories. Inquire for other versions.