

Revolution, Length, Stroke Counters Type 225



- Approved for length counting by the PTB (German Federal Institute für Physics and Technology)
- 6-digit display
- Large digits, 6.5 mm high
- Button reset
- Counter with suspension device
- Adjustable counterweight
- 6-digit display m/dm or m/cm
- Button reset

TECHNICAL DATA

Display	6-digit
Digit height	6.5 mm
Base plate	Zinc plated sheet steel
Case	die-cast metal
Cover	plastic (ASB), grey
Weight	approx. 750 g
	Counter with suspension device and downward weight approx. 2.400 kp. Downward weight can be shifted in order to regulate contact pressure
Counting mode	+ (-), stroke counter: +
Transmission ratio	1:1, length counter 1:5 or 1:50
Max. speed	10000 digits/min, stroke counter 800 strokes/min
Torque	1.2 Ncm, stroke counter 8.0 Ncm
Actuating angle	min. 38°, max. 55° (stroke counter only)
Reset	button reset, secured against unauthorized operation
⚠	Don't push the reset pushbutton during the process

DIMENSIONS

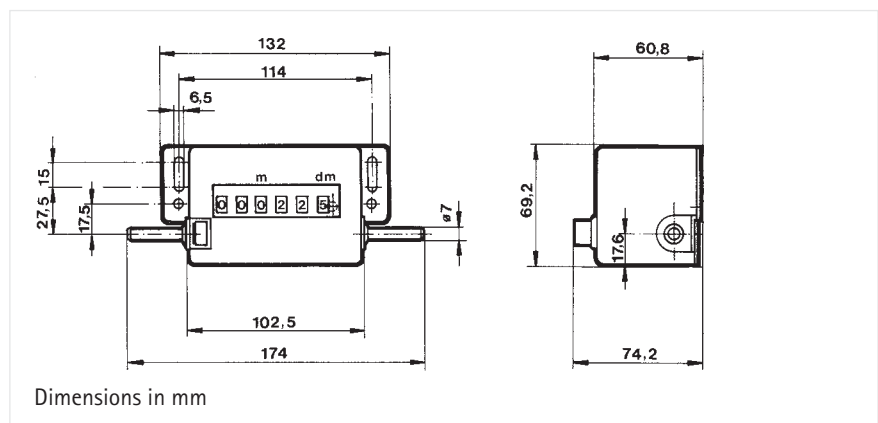

Type 225

Technical data

DIMENSIONS

Counter with suspension device

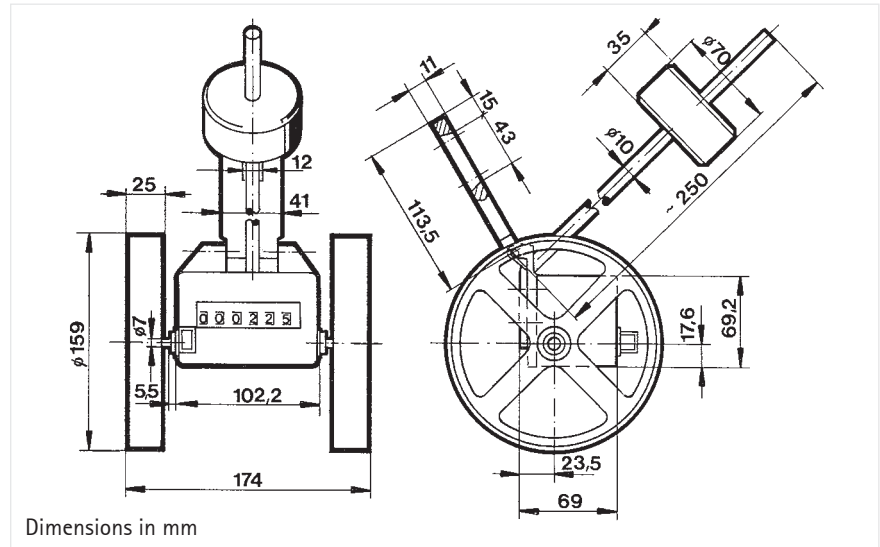

Dimensions in mm

ORDER INFORMATION

	Actuation	Sense of rotation	Indication	Transm. ratio	Transm. ratio	Transm. ratio	Transm. ratio
				1:1	1:5	1:10	1:50
				Ordering code	Ordering code	Ordering code	Ordering code
Revolution counter	1	Bz	999 999	0 225 001	-	0 225 021	-
	1	Bw	999 999	0 225 002	-	0 225 022	-
Length counter	1	Bz	99 999,9 m/dm	-	0 225 003 m/dm	-	0 225 007 m/cm
	1	Bw	99 999,9 m/dm	-	0 225 004 m/dm	-	0 225 008 m/cm
Length counter with suspension device	1	Bz	99 999,9 m/dm	-	0 225 501 m/dm	-	0 225 505 m/cm
	1	Bw	99 999,9 m/dm	-	0 225 502 m/dm	-	0 225 506 m/cm
Stroke counter	1	Bz	999 999	0 225 301	-	-	-
	1	Bw	999 999	0 225 302	-	-	-

Stroke lever Ordering code 0 600 005 For other stroke levers see accessories

Panel frame Ordering code 1 250 056 See accessories for description

* on request

For measuring wheel see accessories, they are not included in normal delivery

Doc No: TTCC225 Rev: 001	Impulse Automation Limited United Kingdom Company Registration 665193	Page
18-11-19		2 of 2