

TECHNICAL DATASHEET

Stainless Steel Encoders AC 59 / 61 - Parallel



- Compact design
- Protection class IP67
- High corrosion resistance
- Robust design
- Resolution up to 26 Bit (14 Bit ST, 12 Bit MT)
- Gray or Binary code
- Encoder monitoring
- Output Tristate short circuit-proof
- Applications: packaging machine for food and beverage, ship equipment (e.g. cranes, winches, cable laying ships), offshore applications



GENERAL INFORMATION

The absolute stainless steel encoders with parallel interface are available in the Versions AC 59 and AC 61.

- AC 59: drawn stainless steel housing, only together with Singleturn
- AC 61: machined housing

TECHNICAL DATA
mechanical

Housing diameter	AC 59: 58 mm AC 61: 61.5 mm
Shaft diameter	9.52 mm / 10 mm (Solid shaft)
Flange (Mounting of housing)	Square flange 63.5 mm
Protection class shaft input (EN 60529)	IP67
Protection class housing (EN 60529)	IP67
Shaft load axial / radial	40 N / 60 N
Max. speed	max. 6000 rpm (continuous), max. 10 000 rpm (short term)
Torque	≤ 1 Ncm
Moment of inertia	approx. 20 gcm ²
Vibration resistance (DIN EN 60068-2-6)	100 m/s ² (10 ... 500 Hz)
Shock resistance (DIN EN 60068-2-27)	1000 m/s ² (6 ms)
Operating temperature	-40 °C ... +100 °C
Storage temperature	-40 °C ... +85 °C
Material shaft	Stainless Steel
Material housing	Stainless Steel
Weight	AC 59: approx. 700 g with 1.5 m cable AC 61: approx. 980 g with 1.5 m cable

TECHNICAL DATASHEET

Stainless Steel Encoders AC 59 / 61 - Parallel

TECHNICAL DATA mechanical (continued)

TECHNICAL DATA electrical

Connection	Cable, axial or radial
Supply voltage	DC 10-30 V On request: DC 5 V
Max. current w/o load	200 mA (ST), 300 mA (MT)
Resolution singleturn	10 - 14 Bit Gray Excess: 360, 720 increments
Resolution multiturn	12 Bit
Output code	Binary, Gray, Gray Excess
Linearity	$\pm \frac{1}{2}$ LSB
Output current	30 mA per Bit, short-circuit-proof
Control inputs	Latch, Direction, Tristate with ST, Tristate with MT
Alarm output	NPN-O.C., max. 5 mA
Status LED	Green = ok, red = alarm

Note: preset key only with MT (IP64), preset value = 0

Data output level

Supply voltage U_B	DC 5 V - 5 % +10 % ¹	DC 10 - 30 V
Output level High	≥ 3.5 V (30 mA) ≥ 3.9 V (10 mA)	$\geq U_B - 2.2$ V (30 mA) $\geq U_B - 1.8$ V (10 mA)
Output level Low	≤ 1.6 V (30 mA) ≤ 1.2 V (10 mA)	≤ 1.6 V (30 mA) ≤ 1.2 V (10 mA)
Rise time (1.5 m Cable)	≤ 0.1 μ s	≤ 0.2 μ s
Drop time (1.5 m Cable)	≤ 0.05 μ s	≤ 0.1 μ s

¹ on request

Control inputs

Input	Level logical (physical)	Function
Direction	1 (+ U_B or open) 0 (0 V)	ascending code values when turning clockwise (cw) descending code values when turning clockwise (cw)
Latch	1 (+ U_B or open) 0 (0 V)	encoder data continuously changing at output encoder data stored and constant at output
Tristate (with singleturn)	1 (+ U_B or open) 0 (0 V)	outputs active outputs at high impedance (Tristate mode)
Tristate (with multiturn)	1 (+ U_B) 0 (0 V or open)	outputs at high impedance (Tristate mode) outputs active

Typical actuating delay time 10 μ s with push-pull selection; when selected via O.C., an external pull-down resistor (1 K Ω) is required

Doc No: AE0014 Rev: 001	Impulse Automation Limited United Kingdom Company Registration 665193	Page 2
2008-04-24 16:01:00		

TECHNICAL DATASHEET

Stainless Steel Encoders AC 59 / 61 - Parallel

ELECTRICAL CONNECTIONS

Singleturn, cable

Colour (PVC)	9 Bit / 360 incr.	10 Bit / 720 incr.	12 Bit	13 Bit	14 Bit
grey/pink	N.C.	N.C.	N.C.	N.C.	S0 (LSB)
brown/yellow	N.C.	N.C.	N.C.	S0 (LSB)	S1
brown/grey	N.C.	N.C.	S0 (LSB)	S1	S2
red/blue	N.C.	N.C.	S1	S2	S3
violet	N.C.	S0 (LSB)	S2	S3	S4
white/brown	S0 (LSB)	S1	S3	S4	S5
white/green	S1	S2	S4	S5	S6
white/yellow	S2	S3	S5	S6	S7
white/grey	S3	S4	S6	S7	S8
white/pink	S4	S5	S7	S8	S9
white/blue	S5	S6	S8	S9	S10
white/red	S6	S7	S9	S10	S11
white/black	S7	S8	S10	S11	S12
brown/green	S8 (MSB)	S9 (MSB)	S11 (MSB)	S12 (MSB)	S13 (MSB)
yellow	$\overline{\text{Tristate S0...S8}}$	$\overline{\text{Tristate S0...S9}}$	$\overline{\text{Tristate S0...S11}}$	$\overline{\text{Tristate S0...S12}}$	$\overline{\text{Tristate S0...S13}}$
pink	$\overline{\text{Latch}}$	$\overline{\text{Latch}}$	$\overline{\text{Latch}}$	$\overline{\text{Latch}}$	$\overline{\text{Latch}}$
green	$\overline{\text{Direction}}$	$\overline{\text{Direction}}$	$\overline{\text{Direction}}$	$\overline{\text{Direction}}$	$\overline{\text{Direction}}$
black	0 V	0 V	0 V	0 V	0 V
red	DC 5 V/ 10-30 V	DC 5 V/ 10-30 V	DC 5 V/ 10-30 V	DC 5 V/ 10-30 V	DC 5 V/ 10-30 V
brown	$\overline{\text{Alarm}}$	$\overline{\text{Alarm}}$	$\overline{\text{Alarm}}$	$\overline{\text{Alarm}}$	$\overline{\text{Alarm}}$

TECHNICAL DATASHEET

Stainless Steel Encoders AC 59 / 61 - Parallel

ELECTRICAL CONNECTIONS

Multiturn, cable (only AC 61 - Parallel)

Cable (TPE)			10 cm cable with Sub-D connector, 37 pole			Cable (TPE)			10 cm cable with Sub-D connector, 37 pole		
Colour	Pin	Connection	Colour	Pin	Connection	Colour	Pin	Connection	Colour	Pin	Connection
brown	2	S0	white/blue	14	M4 ¹						
green	21	S1	brown/blue	33	M5 ¹						
yellow	3	S2	white/red	15	M6 ¹						
grey	22	S3	brown/red	34	M7 ¹						
pink	4	S4	white/black	16	M8 ²						
violet	23	S5	brown/black	35	M9 ²						
grey/pink	5	S6	grey/green	17	M10 ²						
red/blue	24	S7	yellow/grey	36	M11 ²						
white/green	6	S8	pink/green	18	Alarm						
brown/green	25	S9	yellow/pink	10	Direction						
white/yellow	7	S10	green/blue	30	Latch						
yellow/brown	26	S11	yellow/blue	12	Tristate						
white/grey	8	M0	red (0.5mm ²)	13	DC 10-30 V						
grey/brown	27	M1	white (0.5mm ²)	31	DC 10-30 V						
white/pink	9	M2	blue (0.5mm ²)	1	0 V						
pink/brown	28	M3	black (0.5mm ²)	20	0 V						

¹ N. C. with resolution 16 Bit (4 Bit MT)

² N. C. with resolution 16 Bit or 20 Bit (4 or 8 Bit MT)

Doc No: AE0014 Rev: 001	Impulse Automation Limited United Kingdom Company Registration 665193	Page
2008-04-24 16:01:00		4

TECHNICAL DATASHEET

Stainless Steel Encoders AC 59 / 61 - Parallel

DIMENSIONED DRAWINGS

AC 59 Connection cable "A" / "B"
Dimensions in mm

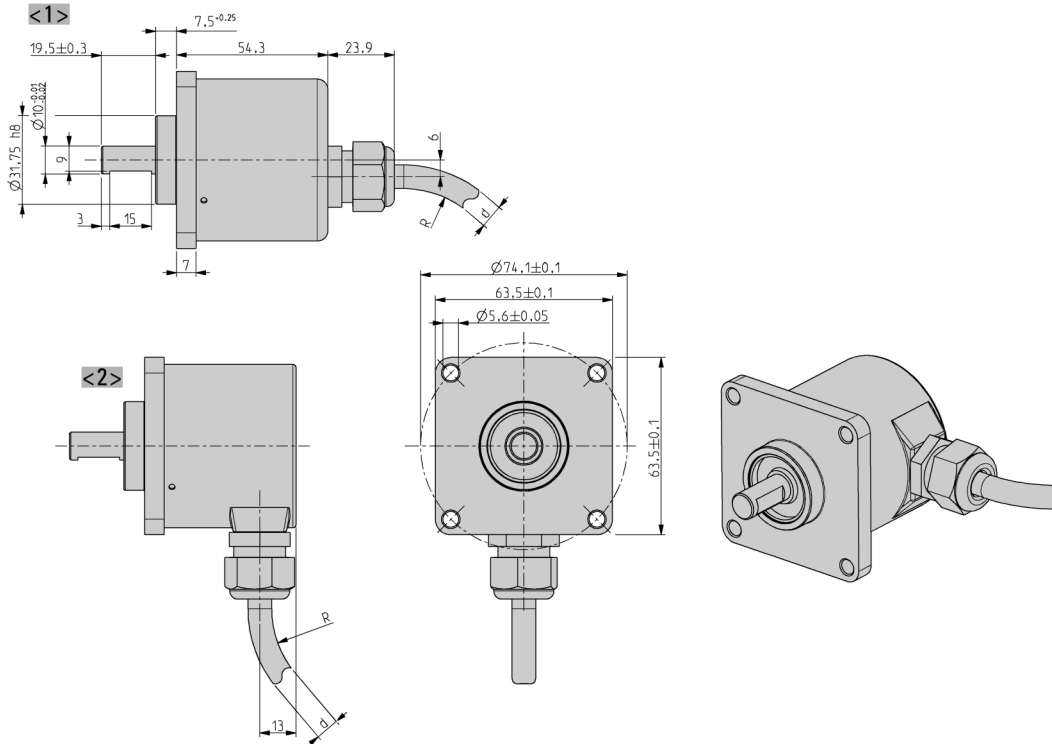

<1> Connection cable "A"
<2> Connection cable "B"
Cable bending radius R for flexible installation $\geq 15 \times$ cable diameter

Cable bending radius R for fixed installation $\geq 7.5 \times$ cable diameter
Cable Ø d BiSS/SSI/SSI-P: $7,1^{+1,2}$
Cable Ø d ST-P: $7,8^{+0,9}$

TECHNICAL DATASHEET

Stainless Steel Encoders AC 59 / 61 - Parallel

ORDERING INFORMATION

Type	Resolution ^{1,2,3}	Supply voltage	Flange, Protection, Shaft	Interface	Connection
<input type="checkbox"/>	<input type="text"/>	<input type="checkbox"/>	<input type="checkbox"/>	<input type="checkbox"/>	<input type="checkbox"/>
AC59 AC61	0010 10 Bit ST 0012 12 Bit ST 0013 13 Bit ST 0014 14 Bit ST 0017 17 Bit ST 0360 360 increments ST 0720 720 increments ST 0412 4 Bit MT + 12 Bit ST (AC 61) 0812 8 Bit MT + 12 Bit ST (AC 61) 1212 12 Bit MT + 12 Bit ST (AC 61)	A DC 5 V E DC 10 - 30 V	Q.76 Square, IP67, 9.52 mm Q.72 Square, IP67, 10 mm	PB Parallel binary PG Parallel Gray	A Cable, axial B Cable, radial

¹ Resolution 360 increments ST with Offset 76 (value range 76...435)

² Resolution 720 increments ST with Offset 152 (value range 152...871)

³ AC59 only with ST (only AC 59)

ORDERING INFORMATION

Selection of cable length

Versions with cable outlet (connection A, B, E or F) are available with various lengths of cable. To order your desired cable length, please add the respective code to the end of your ordering code. Further cable lengths on request.

Code	Cable length
without code	1.5 m
-D0	3 m
-F0	5 m
-K0	10 m
-P0	15 m
-U0	20 m
-V0	25 m

Doc No: AE0014 Rev: 001	Impulse Automation Limited United Kingdom Company Registration 665193	Page
2008-04-24 16:01:00		6

TECHNICAL DATASHEET

Stainless Steel Encoders AC 59 / 61 - Parallel Accessories

FLEXIBLE COUPLINGS



Bellows coupling



Helical coupling



Isolated disk coupling

		Ordering code
Bellows coupling	10 mm / 10 mm	3 520 037
Bellows coupling	8 mm / 10 mm	3 520 077
Helical coupling 25/32	6 mm / 10 mm	3 520 066
Helical coupling 25/32	10 mm / 12 mm	3 520 065
Helical coupling 25/32	10 mm / 10 mm	3 520 074
Isolated disk coupling	6 mm / 10 mm	3 520 082
Isolated disk coupling	10 mm / 10 mm	3 520 088

MEASURING WHEELS

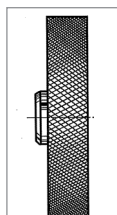

Tread 2 + 3

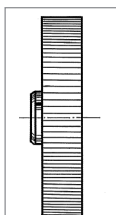

Tread 4

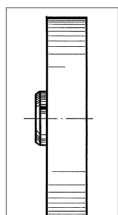

Tread 6

Tread 2 B

with glued-on rubber profile B = low-wear rubber surface with good grip (white)
Applications such as paper and cardboard, measuring cables, nongreasy metals, fleece, undressed or surface-treated wood, soft and hard plastics

Tread 3

vulcanized rubber surface with parallel knurl
Applications such as rubber, leather, fabrics, flooring and glass

Tread 4

Aluminum with parallel knurl
Applications such as rubber, soft plastics, wood with rough surface, and to a limited extent for fabrics

Tread 6

plastic surface
Applications such as wire, greasy metals and steel sections

Material	Bore diameter (mm) fitting to encoder shaft	Circumference	Tread	Width of bearing surface	Ordering code
Aluminum	10 mm	0.2 m	2 B	12 mm	0 601 049
Aluminum	10 mm	0.5 m	2 B	25 mm	0 601 151
Aluminum	10 mm	0.5 m	3	25 mm	0 601 161
Aluminum	12 mm	0.5 m	3	25 mm	0 601 166
Aluminum	10 mm	0.5 m	6	25 mm	0 601 163
Aluminum	10 mm	0.5 yd	4	25 mm	0 601 157