

**TECHNICAL DATASHEET**

**Absolute Motorfeedback Series AD 35**



- Shortest absolute encoder world wide
- Mounting depth: 23.65 mm
- Hub shaft 8 mm
- Resolution up to 22 Bit Singleturn
- +120°C operating temperature
- 10,000 rpm continuous operation
- Interfaces: SSI, BiSS-B or BiSS-C
- Sinewave 1 Vpp
- Bandwidth 500 kHz



**GENERAL INFORMATION**

Hengstler presents the shortest hollowshaft encoder world wide: The AD35. It is available with a 8 mm hub shaft and a resolution up to 22 Bit Singleturn. The mechanical design consists of two ball bearings and a flexible torque support. The AD35 complements the ACURO-DRIVE series and is appropriate for use within BLDC servo motors with small frame sizes.

Further fields of Application:

- Medical
- Measuring instrument
- Military
- Robotics

**Fully digital control loop**

The new and completely digital OptoAsic technology enables the transition to a truly digital drive system. The conventional absolute encoders still have analog sine wave signals for the feedback of speed and position data. The AD35, however, provides fully digital position data up to 22 Bit over the BiSS interface with a variable clock rate up to 10 MHz. BiSS is the only open high speed bidirectional sensor interface available on the market. Backward compatibility to most of the existing drives is realized through the variant with SSI interface together with 2048 sine -cosine periods per revolution.

**Integrated diagnostic system**

The AD35 has an integrated diagnostic system that controls and regulates the internal signals. Maximum motor uptime is achieved through the pre warning in case of any system error or aging effects well before they affect the function of the encoder. A code plausibility check guarantees that the output data represents always the true position. Also the operating temperature can be measured and read out with 8 Bit resolution. If programmable limits are exceeded or under run this is indicated over warn and alarm bits.

**TECHNICAL DATA**  
**mechanical**

Housing diameter	37.5 mm
Shaft diameter	8 mm (Hubshaft)
Flange (Mounting of housing)	Tether
Protection class shaft input (EN 60529)	IP40
Protection class housing (EN 60529)	IP40
Axial endplay of mounting shaft (hubshaft)	± 0.5 mm
Radial runout of mating shaft (hubshaft)	± 0.05 mm

## TECHNICAL DATASHEET

### Absolute Motorfeedback Series AD 35

#### TECHNICAL DATA mechanical (continued)

Max. speed	max. 10 000 rpm (continuous), max. 12 000 rpm (short term)
Starting torque typ.	≤ 1 Ncm
Moment of inertia	ca. 2.5 x 10 <sup>-6</sup> kgm <sup>2</sup>
Vibration resistance (DIN EN 60068-2-6)	100 m/s <sup>2</sup> (10 ... 2000 Hz)
Shock resistance (DIN EN 60068-2-27)	1000 m/s <sup>2</sup> (6 ms)
Operating temperature	-15 °C ... +120 °C
Storage temperature <sup>1</sup>	-15 °C ... +85 °C
Material housing	Plastic
Weight	approx. 80 g (ST)
Connection	Cable, radial PCB connector, 12 pole

<sup>1</sup> due to packing

#### TECHNICAL DATA electrical

Supply voltage	DC 5 V -5 %/+10 % or DC 7 - 30 V
Current w/o load typ.	100 mA
Resolution singleturn	12 - 22 Bit
Resolution multiturn	12 Bit
Output code	Gray
Drives	Clock and Data / RS422
Incremental signals	Sinus-Cosinus 1 Vpp
Number of pulses	2048
3dB limiting frequency	500 kHz
Absolute accuracy	±35"
Repeatability	±10"
Alarm output	Alarm bit (SSI Option), warning and alarm bit (BiSS)

#### ELECTRICAL CONNECTIONS PCB connector, 12 pole

Color	PIN	Signals
grey	1a	Data
white/ green <sup>1</sup>	2a	A+
black <sup>1</sup>	3a	0 V sensor
red/ blue <sup>1</sup>	4a	B+
green	5a	Clock
pink <sup>1</sup>	6a	5 V Sensor
white	1b	DC 5 V/ 7 - 30 V
yellow	2b	Clock
grey/ pink <sup>1</sup>	3b	B-
brown	4b	0 V (U <sub>N</sub> )
brown/ green <sup>1</sup>	5b	A-
pink	6b	Data

<sup>1</sup> Analog signals (1 Vpp) only available with interface SC (SSI Gray + 1 Vpp) and BC (BiSS + 1 Vpp).

## TECHNICAL DATASHEET

### Absolute Motorfeedback Series AD 35

#### CONNECTION ENCODER SIDE

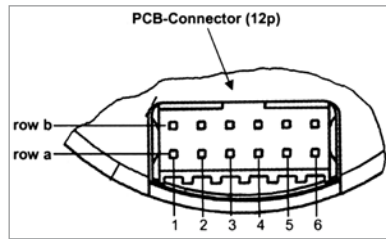

12 pin PCB connector  
manufacture Berg, type Minitek

#### DIMENSIONED DRAWINGS

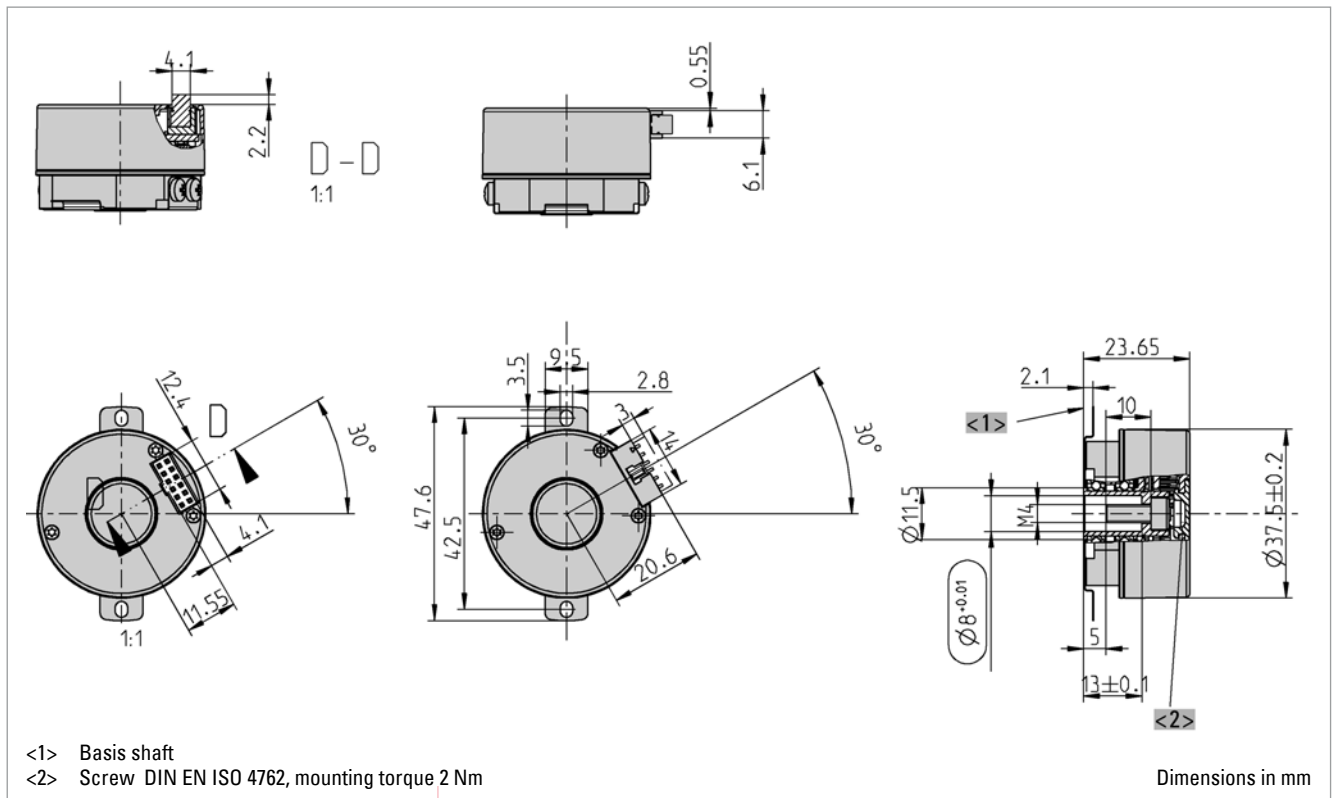

## TECHNICAL DATASHEET

### Absolute Motorfeedback Series AD 35

#### ORDERING INFORMATION

Type	Resolution	Supply voltage <sup>1</sup>	Flange, Protection, Shaft	Interface	Connection
<input type="checkbox"/>	<input type="checkbox"/>	<input type="checkbox"/>	<input type="checkbox"/>	<input type="checkbox"/>	<input type="checkbox"/>
<b>AD35</b>	<b>0012</b> 12 Bit ST <b>0013</b> 13 Bit ST <b>0014</b> 14 Bit ST <b>0017</b> 17 Bit ST <b>0019</b> 19 Bit ST (BiSS) <b>0022</b> 22 Bit ST (BiSS)	<b>A</b> DC 5 V <b>E</b> DC 7 - 30 V	<b>F.0R</b> Spring tether, IP40, 8 mm hub shaft	<b>BI</b> BiSS-B <b>BC</b> BiSS-B (+SinCos 1Vpp) <b>SG</b> SSI Gray <b>SC</b> SSI Gray (+SinCos 1Vpp) <b>BE</b> BiSS-C <b>BV</b> BiSS-C (+SinCos 1Vpp)	<b>0</b> PCB connector, axial, 12 pole <b>2</b> PCB connector, radial, 12 pole <b>A</b> PCB connector, axial, 12 pole with mating connector and 0.5 m cable <b>B</b> PCB connector, radial, 12 pole, with mating connector and 0.5 m cable

<sup>1</sup> No inverse-polarity protection for 5 V power supply