

Basics of Absolute Encoders ACURO

DeviceNet

BACKGROUND AND TECHNOLOGY

Background

- The basic technology was developed by Allen-Bradley
- Introduced in March 1994
- The ODVA (Open DeviceNet Vendor Association) was founded in April 1995

Technology

- CAN-Layer 2 (Data Link Layer) - ISO 11898 and 11519-1
- DeviceNet covers layer 7 (Application Layer) and layer 1 (Physical Layer), developed for industrial automation

Main benefits

- Reduced cabling and installation effort
- Reduced run-in time
- Reduced down-time
- Fast error elimination
- Devices can be removed, replaced and inserted without having to shut the network down
- Devices from various manufacturers can be exchanged
- Devices are configured over the network

LINEAR BUS TOPOLOGY

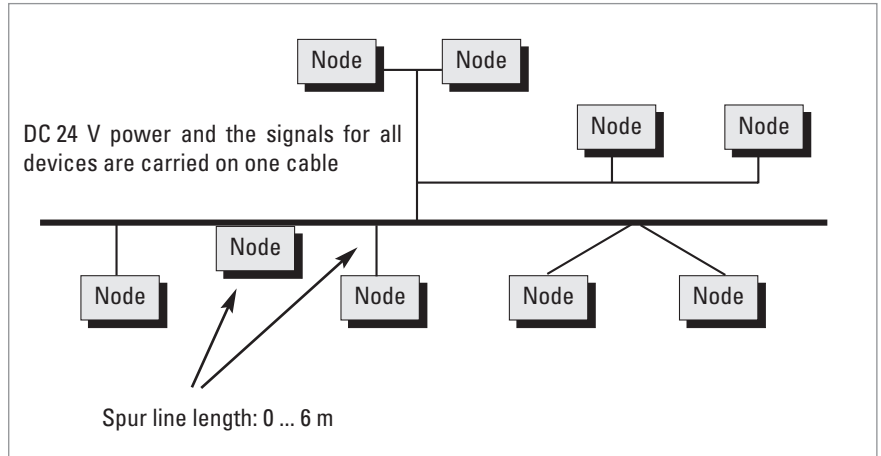

NETWORK SPECIFICATION

