

TECHNICAL DATASHEET

Incremental Encoder RI 30-0



- Miniature encoder for industrial use
- Low current consumption
- High noise interference immunity
- Cable lengths of up to 100 m
- Suitable for high pulse frequencies
- High protection class
- Applications: CNC machines, manipulators, motors, medical technology, textile machines



NUMBER OF PULSES

5 / 10 / 20 / 25 / 30 / 50 / 60 / 100 / 120 / 200 / 250 / 256 / 288 / 300 / 360 / 400 / **500** / **512** / 600 / 720 / **1000** / 1024 / 1250 / 1500

Other number of pulses on request

Preferably available versions are printed in bold type.

TECHNICAL DATA mechanical

Housing diameter	30 mm
Shaft diameter	5 mm (Solid shaft)
Flange (Mounting of housing)	Synchro flange, Pilot flange
Protection class shaft input (EN 60529)	IP64
Protection class housing (EN 60529)	IP64
Shaft load axial / radial	5 N / 10 N
Max. speed	max. 10 000 rpm
Starting torque typ.	≤ 1 Ncm
Moment of inertia	approx. 0.8 gcm ²
Vibration resistance (DIN EN 60068-2-6)	100 m/s ² (10 ... 2000 Hz)
Shock resistance (DIN EN 60068-2-27)	1000 m/s ² (6 ms)
Operating temperature	-10 °C ... +70 °C
Storage temperature	-25 °C ... +85 °C
Material housing	Aluminum
Weight	approx. 60 g
Connection	Cable, axial or radial M16 (Binder), axial

TECHNICAL DATA electrical

General design	as per DIN VDE 0160, protection class III, contamination level 2, overvoltage class II
Supply voltage	RS422 + Alarm (R), RS422 + Sense (T): DC 5 V ±10 % Push-pull (K): ± 10% DC 5 V or DC 10 - 30 V
Current w/o load typ.	40 mA (DC 5 V), 60 mA (DC 10 V), 30 mA (DC 24 V)
Max. pulse frequency	RS422: 300 kHz Push-pull: 200 kHz
Standard output versions ¹	RS422 + Alarm (R): A, B, N, \bar{A} , \bar{B} , \bar{N} , \bar{Alarm} RS422 + Sense (T): A, B, N, A, B, N, Sense Push-pull (K): A, B, N, \bar{Alarm}
Pulse width error	± max. 25° electrical
Number of pulses	5 ... 1500

TECHNICAL DATASHEET

Incremental Encoder RI 30-0

TECHNICAL DATA
electrical (continued)

Alarm output	NPN-O.C., max. 5 mA
Pulse shape	Square wave
Pulse duty factor	1:1

¹ With push-pull (K): pole protection

ELECTRICAL CONNECTIONS
Cable

Description (push-pull)	Description (RS422)	Lead \square mm ²	Colour
DC 10 - 30 V	DC 5 V	0.5	red
	Sense V _{cc}	0.14	yellow/red
Channel A	Channel A	0.14	white
	Channel \bar{A}	0.14	white/brown
Channel B	Channel B	0.14	green
	Channel \bar{B}	0.14	green/brown
Channel N	Channel N	0.14	yellow
	Channel \bar{N}	0.14	yellow/brown
GND	GND	0.5	black
Alarm	Alarm/Sense GND ¹	0.14	yellow/black
screen ²	screen ²		screen ²

¹ depending on ordering code

² connected with encoder housing

ELECTRICAL CONNECTIONS
M16 connector (Binder), 6 pole

Description (push-pull)	Pin
DC 10 - 30 V	1
Channel A	2
Channel N	3
Channel B	4
\bar{A} Alarm	5
GND	6

TECHNICAL DATASHEET

Incremental Encoder RI 30-0

DIMENSIONED DRAWINGS

Synchro flange. cable

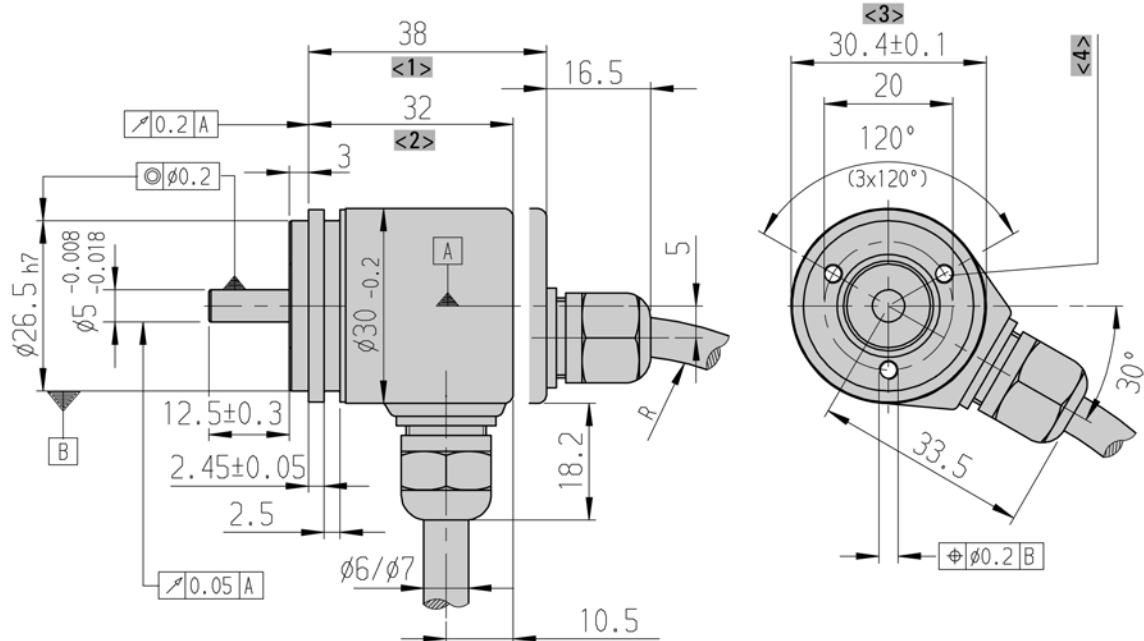

- <1> axial
- <2> radial
- <3> Housing

- <4> mounting thread M3x5
- Cable bending radius R for flexible installation ≥ 100 mm
- Cable bending radius R for fixed installation ≥ 40 mm
- Dimensions in mm

Pilot flange. cable

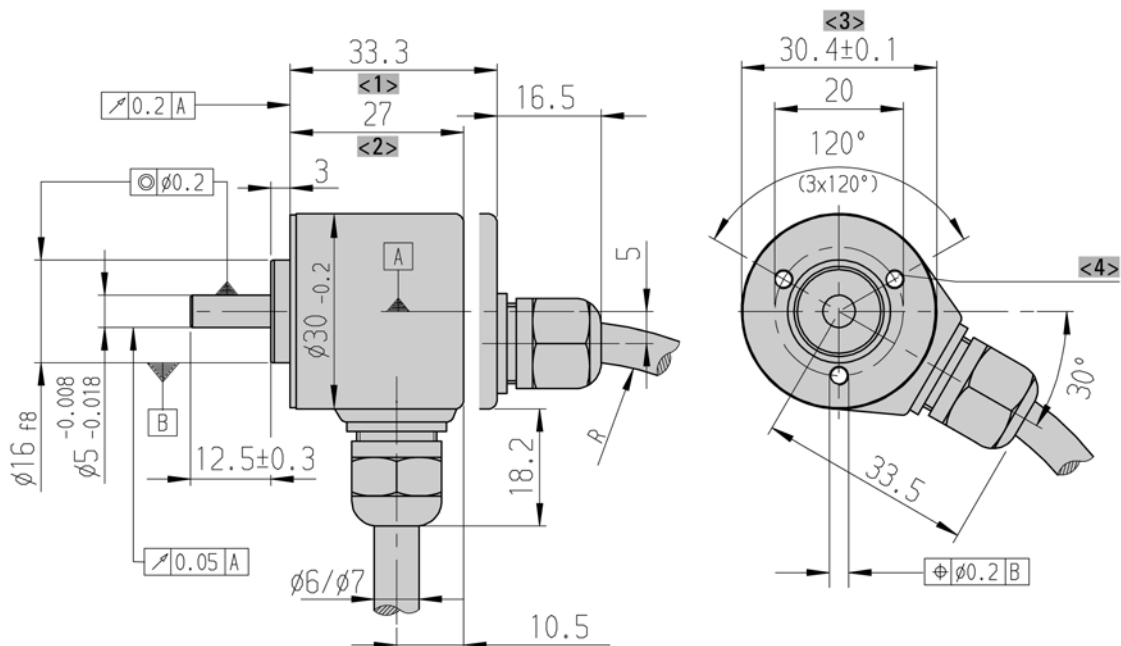

- <1> axial
- <2> radial
- <3> Housing

- <4> mounting thread M3x5
- Cable bending radius R for flexible installation ≥ 100 mm
- Cable bending radius R for fixed installation ≥ 40 mm
- Dimensions in mm

TECHNICAL DATASHEET

Incremental Encoder RI 30-0

DIMENSIONED DRAWINGS (continued)

Synchro flange. M16 (Binder)

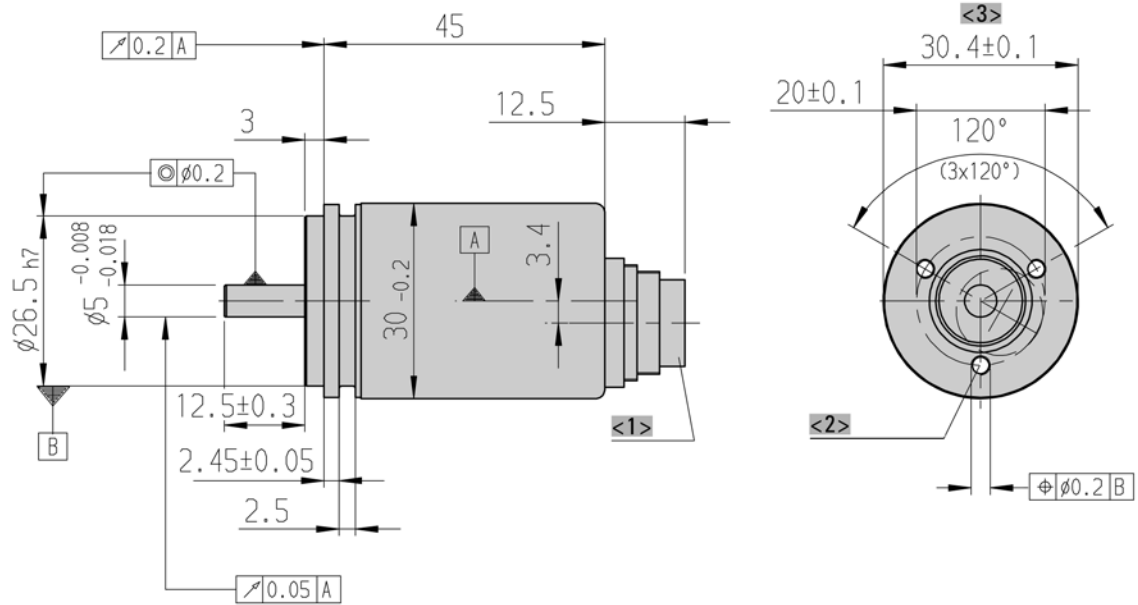

- <1> 6 pole (pins)
- <2> mounting thread M3x5

<3> Housing

Dimensions in mm

Pilot flange. M16 (Binder)

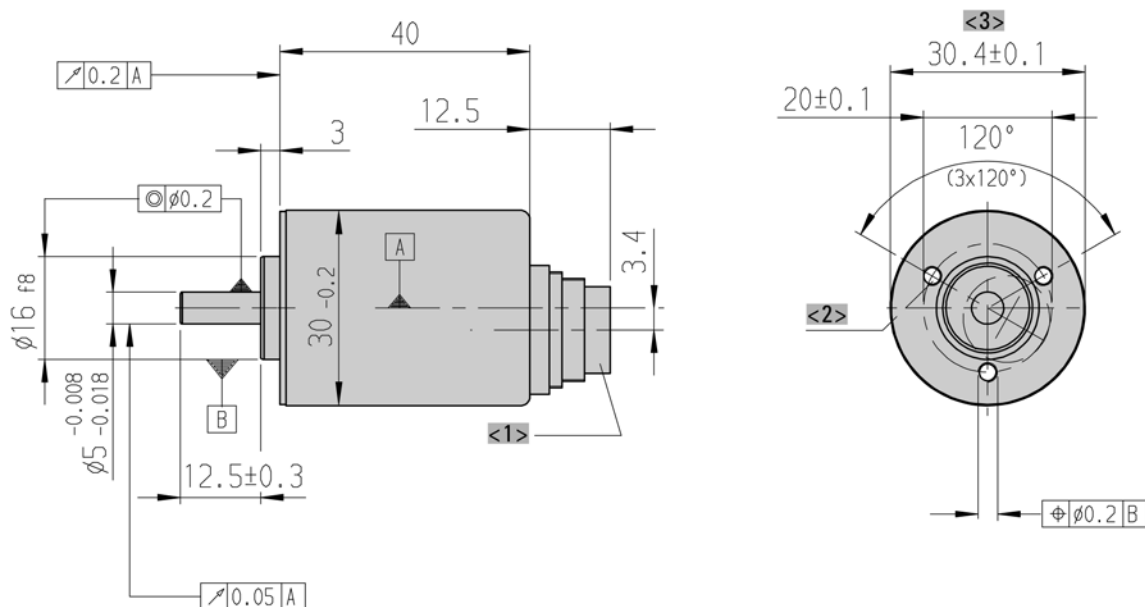

- <1> 6 pole (pins)
- <2> mounting thread M3x5

<3> Housing

Dimensions in mm

TECHNICAL DATASHEET

Incremental Encoder RI 30-0

ORDERING INFORMATION

Type	Number of pulses	Supply voltage ¹	Flange, Protection, Shaft	Output ²	Connection ³
<input type="checkbox"/>	<input type="checkbox"/>	<input type="checkbox"/>	<input type="checkbox"/>	<input type="checkbox"/>	<input type="checkbox"/>
RI30-0	5 ... 1500	A DC 5 V E DC 10 - 30 V	S.34 Synchro, IP64, 5 mm R.34 Pilot, IP64, 5 mm	R RS422 +Alarm T RS422 +Sense K Push-pull	A Cable, axial B Cable, radial E-I M23 connector (Conin) at 1 m TPE cable, cw E-D M23 connector (Conin) at 1 m TPE cable, ccw N M16 connector (Binder), 6 pole, axial

¹ DC 10 - 30 V only with push-pull

² Output code "K": short-circuit-proof

³ For Output Code "N" (M16): only push-pull

ORDERING INFORMATION

Selection of cable length

Versions with cable outlet (connection A, B, E or F) are available with various lengths of cable. To order your desired cable length, please add the respective code to the end of your ordering code. For variants with connector on cable end please add cable length code in between. Further cable lengths on request.

Code	Cable length
without code	1.5 m
-D0	3 m
-F0	5 m
-K0	10 m
-P0	15 m
-U0	20 m
-V0	25 m

Example:

Cable 3 m length: ... B - D0

Cable mit 3 m length and M23 connector, cw: ... B - D0 - I

TECHNICAL DATASHEET

Incremental Encoder RI 30-0 Accessories

FLEXIBLE COUPLINGS



		Ordering code
Helical coupling 19/28	5 mm / 5 mm	3 520 036
Helical coupling 19/28	5 mm / 6 mm	3 520 035
Plastic coupling	5 mm / 5 mm	3 520 034

MOUNTING

	Ordering code
Clamping eccentric for synchro flange, for M2,5 (set of three)	0 070 654

CONNECTORS

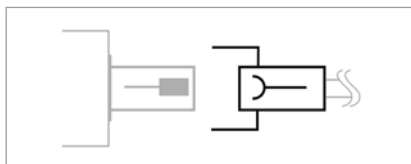

Connector (socket) matching with encoder connector	Ordering code
M16 (Binder), 6 pole, bent, IP40, mating connector for connection J/N	3 539 209
M16 (Binder), 6 pole, gerade, IP67, mating connector for connection J/N	3 539 472
M23 (Conin), 12 pole, PG9, cw, mating connector for connection C/D/-I	3 539 202

CONNECTORS

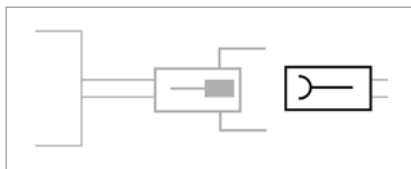

Coupling (socket) matching with encoder cable with connector	Ordering code
M23 (Conin), 12 pole, cw, mating connector for connection -C (cable plug 3 539 186)	3 539 187

CONNECTORS

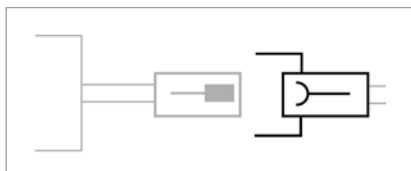

Connector (socket) matching with encoder cable with connector	Ordering code
M23 (Conin), 12 pole, ccw, mating connector for connection G/H/-D/-H	3 539 229

CONNECTING CABLES

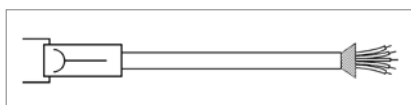

Connecting cables with plug (socket) on one end	Ordering code
M16 (Binder), 6 pole, PVC cable, mating connector for connection J/N, 3 m	1 522 405
M16 (Binder), 6 pole, PVC cable, mating connector for connection J/N, 5 m	1 522 404
M16 (Binder), 6 pole, PVC cable, mating connector for connection J/N, 10 m	1 522 340
M16 (Binder), 6 pole, PVC cable, mating connector for connection J/N, 15 m	1 522 833

Doc No: IE0501 Rev: 001	Impulse Automation Limited United Kingdom Company Registration 665193	Page
2011-09-06 13:58:54		6

TECHNICAL DATASHEET

Incremental Encoder RI 30-0

Accessories

CONNECTING CABLES (continued)

Connecting cables with plug (socket) on one end	Ordering code
M16 (Binder), 6 pole, PVC cable, mating connector for connection J/N, 50 m	1 522 836
M23 (Conin), 12 pole, TPE cable, cw, mating connector for connection C/D/-I, 3 m	1 522 348
M23 (Conin), 12 pole, TPE cable, cw, mating connector for connection C/D/-I, 5 m	1 522 349
M23 (Conin), 12 pole, TPE cable, cw, mating connector for connection C/D/-I, 10 m	1 522 350
M23 (Conin), 12 pole, TPE cable, cw, mating connector for connection C/D/-I, 15 m	1 522 454
M23 (Conin), 12 pole, TPE cable, cw, mating connector for connection C/D/-I, 20 m	1 522 456
M23 (Conin), 12 pole, TPE cable, cw, mating connector for connection C/D/-I, 25 m	1 522 457
M23 (Conin), 12 pole, TPE cable, cw, mating connector for connection C/D/-I, 30 m	1 522 464
M23 (Conin), 12 pole, TPE cable, cw, mating connector for connection C/D/-I, 40 m	1 522 643
M23 (Conin), 12 pole, TPE cable, cw, mating connector for connection C/D/-I, 50 m	1 522 793
M23 (Conin), 12 pole, TPE cable, ccw, mating connector for connection G/H/-D/-H, 3 m	1 522 394
M23 (Conin), 12 pole, TPE cable, ccw, mating connector for connection G/H/-D/-H, 5 m	1 522 395
M23 (Conin), 12 pole, TPE cable, ccw, mating connector for connection G/H/-D/-H, 10 m	1 522 396
M23 (Conin), 12 pole, TPE cable, ccw, mating connector for connection G/H/-D/-H, 15 m	1 522 447
M23 (Conin), 12 pole, TPE cable, ccw, mating connector for connection G/H/-D/-H, 20 m	1 522 461
M23 (Conin), 12 pole, TPE cable, ccw, mating connector for connection G/H/-D/-H, 25 m	1 522 462
M23 (Conin), 12 pole, TPE cable, ccw, mating connector for connection G/H/-D/-H, 30 m	1 522 463
M23 (Conin), 12 pole, TPE cable, ccw, mating connector for connection G/H/-D/-H, 40 m	1 522 463

CONNECTING CABLES

Cable not made up with connectors	Ordering code
PVC cable, 10-core + screen	3 280 114 + length
PVC cable, 6-core + screen	3 280 113 + length
TPE cable, 12-core + screen	3 280 112 + length