

Pneumatic Totalising Counter

6 Digit Pneumatic Counter Surface Mounting

Technical information

Pressure range:	2 - 8 bar
Temperature range:	0°C...+60°C
Mounting:	Surface mounting only
Mechanical life:	30 x 10 ⁶
Display:	4mm digit height, 1 line of 6 digits
Protection class:	IP40 when connected.
Count frequency:	25Hz (Non-pulse period must drop to 0.15 bar for a minimum of 12ms)
Count pulse length:	8ms minimum
Manual reset:	Top button reset
Pneumatic reset:	Pulse signal to port Y, min pulse length 180ms
Operating medium:	5 micron filtered, non-lubricated compressed air



Description	Ports	Order code
6 digit adding totalising counter	M5	50.660

Dimensional drawings

Pneumatic totalising counters display the total count of pneumatic pulses.

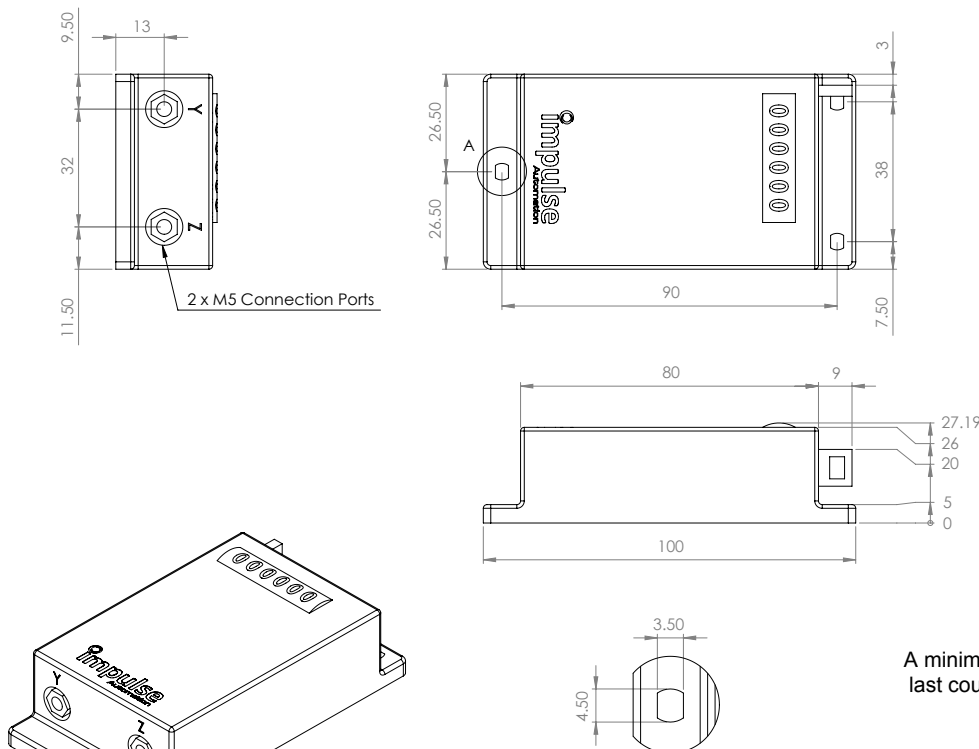

DETAIL A
 SCALE 2 : 1
 Typical Hole Dimensions

Important note:
 A minimum time period between the last count pulse and the pneumatic reset is 50ms.

Impulse Automation Limited
United Kingdom
Company Registration 665193