

Pneumatic Timer - ON Delay Timing

Pneumatic Mini Timer - Panel or DIN Rail Mounting

Technical information

Pressure range:	2-6 bar
Display type:	Digit roll
IP rating:	IP40 when connected, higher protection with covers (front only)
Panel cut out:	45 x 22.2mm
Temperature range:	0°C...+60°C
Mounting:	Panel mount, includes clip (base or DIN-rail with accessories)
Time setting:	Via front rotary knob
Reset:	Automatic - by removal of pressure port 1
Reset time:	200ms
Operating medium:	5 micron filtered clean dry, non-lubricated compressed air



Description	Repeatability	Setting accuracy	Ports	Order code
0.2 to 3 seconds 3/2 way (ON delay) normally closed timing	+/- 0.1 s	+/- 0.3 s	M5	51.020.33.00
2 to 30 seconds 3/2 way (ON delay) normally closed timing	+/- 0.3 s	+/- 0.6 s	M5	51.020.03.00
8 to 120 seconds 3/2 way (ON delay) normally closed timing	+/- 1.2 s	+/- 3.0 s	M5	51.020.34.00
20 to 300 seconds 3/2 way (ON delay) normally closed timing	+/- 3.0 s	+/- 6.0 s	M5	51.020.30.00

Dimensional drawings

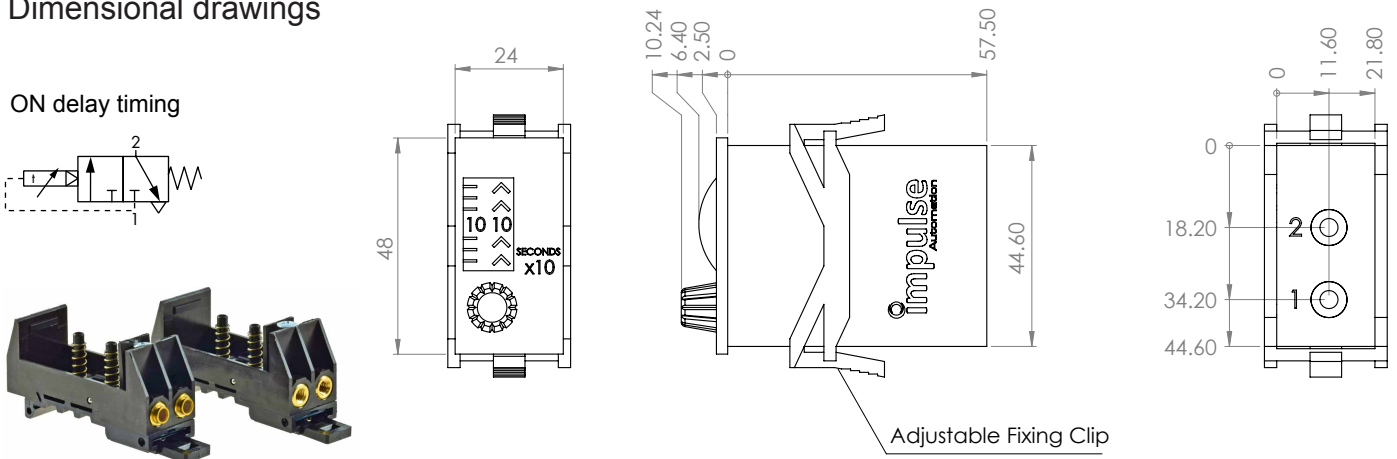

Accessories

IP65 transparent sealing covers (Size 1)

Hinged cover with lock	Order code: 1.405.612
Hinged cover with knob	Order code: 1.405.611

DIN rail mount - 35mm top hat rail

M5 female threaded ports	Order code: 51.031.00.00
4mm instant push-in fittings	Order code: 51.031.00.01

Panel frame (W) 60mm x (H) 75mm

Panel cutout 52mm x 52mm	Order code: 1.499.512 **
--------------------------	---------------------------------

** Hinged covers are available for use with the 1.499.512 panel frame, size 2 only. Part reference **1.405.613** with knob or **1.405.614** with lock.

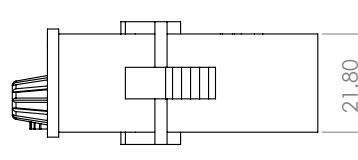

Impulse Automation Limited
United Kingdom
Company Registration 665193