

Compact Pneumatic Cylinder

Double Acting Ø 32mm - 100mm Through Rod

Technical information (Female Threaded Rod)

Operating Pressure: Max. 10 bar
Temperature range: -20°C...+80°C
Housing/end caps: Aluminium tube/die-cast aluminium.
Rod: Stainless steel.
Seals: PUR
Lubricant: Not required.
Operating medium: 5 micron filtered, lubricated or non-lubricated compressed air.



Other information:

 For ATEX certification use code "X" for example 19.X.134.XXX
 Sensors are available for this product, see data sheets TX1000/TX1001.
 Mountings are available for this product, see data sheets MS1002/MS1003.

Piston dia. mm	Stroke mm	D	D1	D2	D3	E1	F	F1	H	H1	H2	L	L1	L2	SW	T	W	Pe min./ bar
32	5 - 300	12	5,5	M6	M6	G1/8	8	36,5	44,5	50,5	21,5	50	32	52	10	12	6	0,6
40	5 - 300	12	5,5	M6	M6	G1/8	8	37,5	45,5	52	21,5	60	42	62,5	10	12	6,5	0,6
50	10 - 300	16	6,5	M8	M8	G1/8	8	37,5	45,5	53	22	68	50	71	13	12	7,5	0,6
63	10 - 300	16	8,5	M10	M8	G1/8	8	42	50	57,5	24,5	87	62	91	13	12	7,5	0,6
80	10 - 400	20	8,5	M10	M10	G1/8	8,5	47,5	56	64	27,5	107	82	111	17	16	8	0,6
100	10 - 400	25	8,5	M10	M12	G1/4	10,5	56	66,5	76,5	32,5	128	103	133	22	20	10	0,6

Dimensional drawings & ordering information

Minimum/maximum strokes apply, see table.

To order: **19.134.XXX** 32mm bore + stroke (Magnetic)
19.234.XXX 40mm bore + stroke (Magnetic)
19.334.XXX 50mm bore + stroke (Magnetic)
19.434.XXX 63mm bore + stroke (Magnetic)
19.534.XXX 80mm bore + stroke (Magnetic)
19.634.XXX 100mm bore + stroke (Magnetic)

Non-magnetic versions are also available for example 19.X36.XXX

Seal kits (without magnet).

Order code: **19.108.11** 32mm bore
 Order code: **19.208.11** 40mm bore
 Order code: **19.308.11** 50mm bore
 Order code: **19.408.11** 63mm bore
 Order code: **19.508.11** 80mm bore
 Order code: **19.608.11** 100mm bore

Technical Data:

Piston dia. mm	Forward force		Return force	
	6 bar N _{max.}	6 bar N _{max.}	6 bar N _{max.}	6 bar N _{max.}
32	415	415	415	415
40	686	686	686	686
50	1057	1057	1057	1057
63	1749	1749	1749	1749
80	2828	2828	2828	2828
100	4418	4418	4418	4418

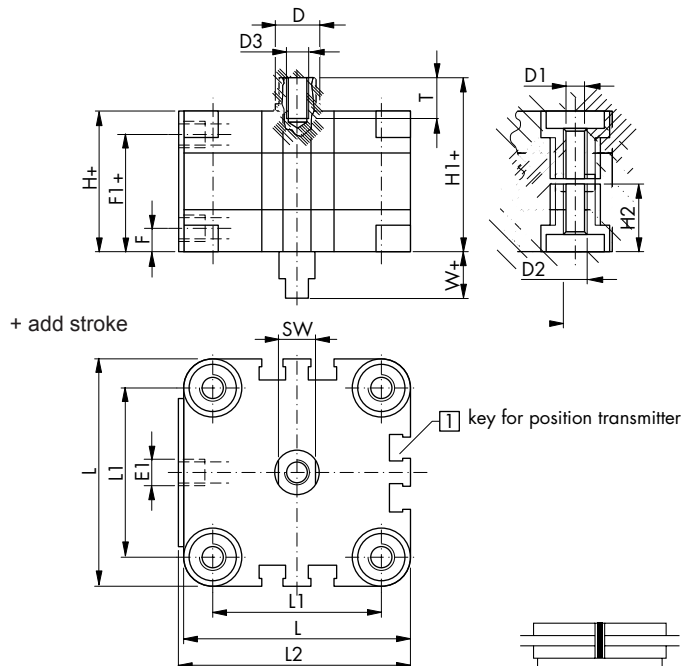

Impulse Automation Limited
 United Kingdom
 Company Registration 665193