

Kuhnke Clamping Cylinder

Single Acting Cylinder Ø 8mm - 20mm

Technical information

Operating pressure: Ø 8mm = 2-10 bar/Ø 12 & Ø 20mm = 1.5-10 bar
Temperature range: -10°C...+70°C
Housing: Aluminium alloy
Rod/cap: Steel corrosion resistant/brass
Seals: Perbunan
Lubricant: Shell Tellus C10
Operating medium: 5 micron filtered, lubricated or non-lubricated compressed air.



Piston dia. mm											Order No.	
											Standard strokes (mm)	
	4		10									
8	39.110.004											
12	39.120.004		39.120.010									
20	39.130.004		39.130.010									

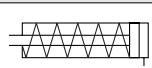

Dimensions

*The stroke is to be limited externally if exceeding the mass shown.

Ø Piston dia. mm	Stroke	A	B	C	D	E	F	G	H Ø	J Ø	K	L Ø	M	N	O	P	X	T	SW	Pressure force (N) at 6 bar	Version	Mass* g	
8	4	20	18	15	11	13,5	8	10	6	3,4		4	3,2	M5		4,9				25	I		
12	4	25	20	15	13	16	9	10	6	3,4		5	3,4	M5		4,6				55	I	25	
12	10	25	20	23	13	16	9	18	6	3,4		5	3,4	M5		4,6				55	I	25	
20	4	40	32	20	20	24	15	5	10	5,5	M5	10	5,5	M5					8	8	165	II	75
20	10	40	32	26	20	24	15	5	10	5,5	M5	10	5,5	M5					8	8	165	II	75

Dimensional drawings

Spare seal kits: 8mm bore
 12mm bore
 20mm bore

Order code: **39.601.01**
 Order code: **39.601.02**
 Order code: **39.601.03**

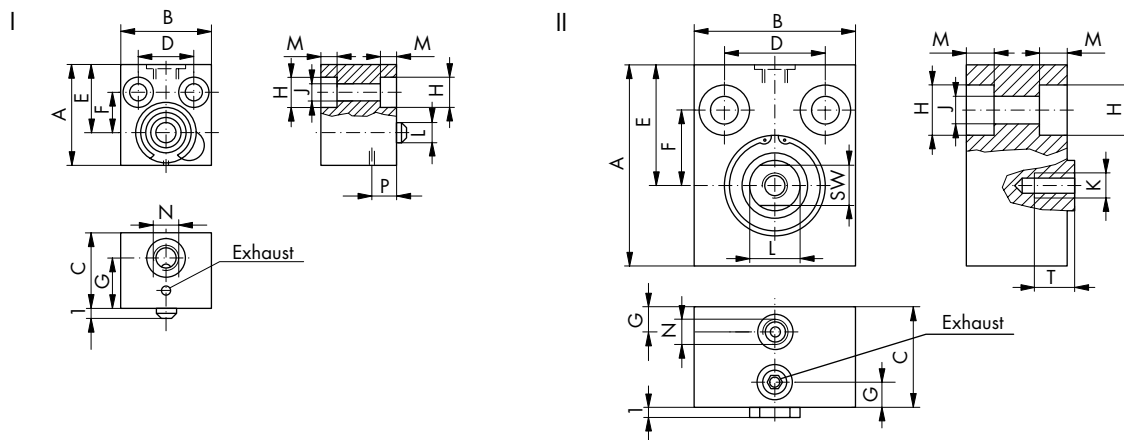

Impulse Automation Limited
United Kingdom
Company Registration 665193