

Miniature Pneumatic Valves

Kuhnke 79 Series Valve - Button, Roller & Whisker

Technical information

Actuation force @ 6 bar: Approx. 0.25N (0.05N at tip for whisker type)
Actuation stroke: Approx. 1 mm for button & roller ball types
Air consumption @ 6 bar: Approx. 2 l/min
Pressure range: 2-10 bar - air pilot assisted
Temperature range: 0°C...+70°C
Housing: Aluminium alloy/Zinc alloy/Makrolon
Spool & liner: Steel, corrosion resistant
Lubricant: Not required
Operating medium: 5 micron filtered, lubricated or non-lubricated compressed air.

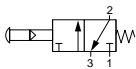
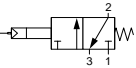
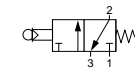

Symbol	Description	Type	Orifice	Ports	Order code
	3/2 way button operated spring return normally closed	Spool	2mm	M5	79.027
	3/2 way whisker operated spring return normally closed	Spool	2mm	M5	79.028
	3/2 way roller ball operated spring return normally closed	Spool	2mm	M5	79.029

Dimensional drawings

Spare whiskers are available

Order code: MM4920003

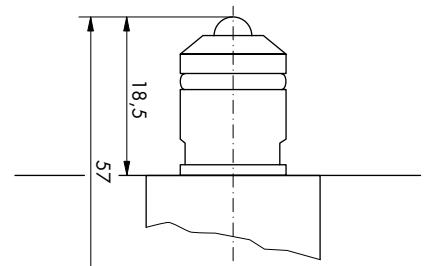
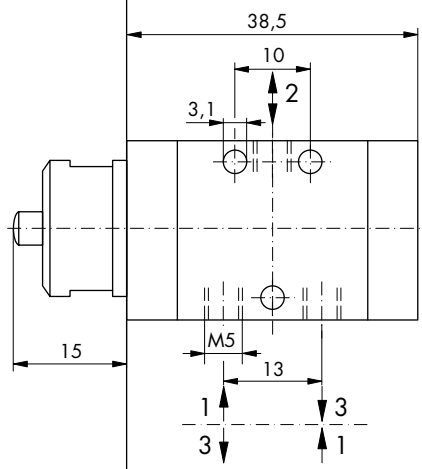
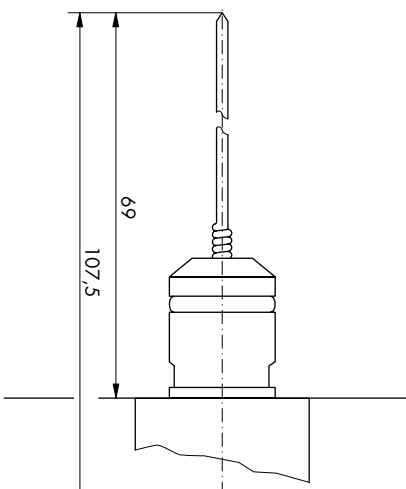

kv=1,80 l/min (NW 2)

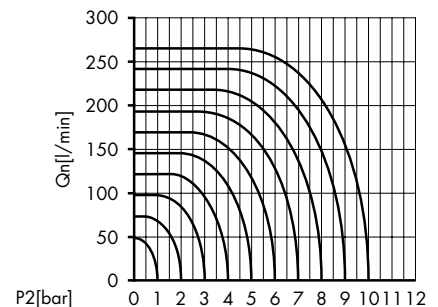

Impulse Automation Limited
United Kingdom
Company Registration 665193