

# Miniature Pneumatic Valves

## Kuhnke 81 Series Valve - Two Way Roller Lever

### Technical information

<b>Actuation force:</b>	Approx. 5N
<b>Pressure range:</b>	0-10 bar
<b>Temperature range:</b>	-10°C...+70°C
<b>Housing:</b>	Aluminium alloy/Zinc alloy/Makrolon
<b>Spool &amp; liner:</b>	Steel, corrosion resistant
<b>Lubricant:</b>	Not required
<b>Operating medium:</b>	5 micron filtered, lubricated or non-lubricated compressed air



Symbol	Description	Type	Orifice	Ports	Order code
	5/2 way roller (two way) spring return	Spool	2mm	M5	<b>81.022</b>

### Dimensional drawings

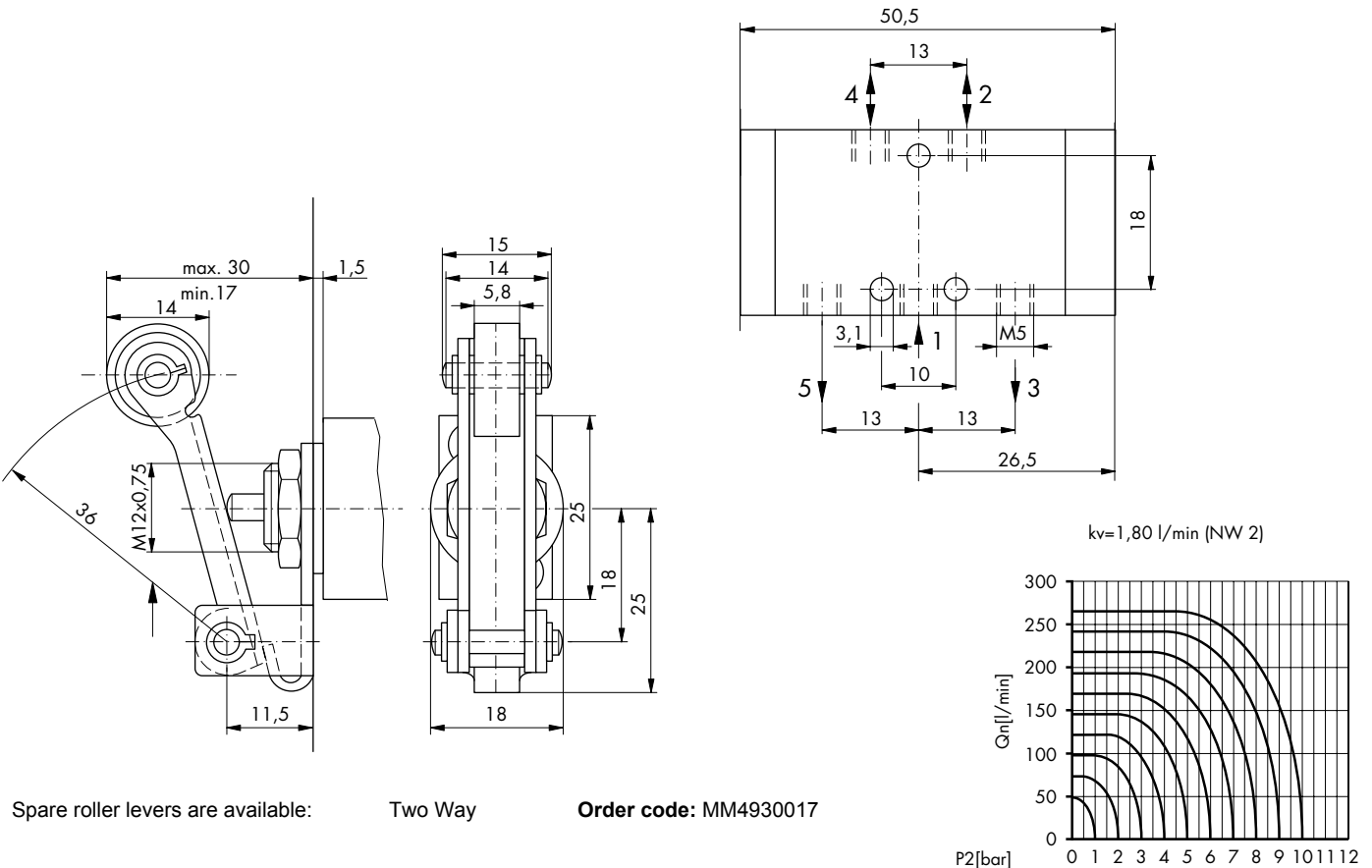

**Impulse Automation Limited**  
**United Kingdom**  
**Company Registration 665193**