

HU32 Series Linear Solenoid Push or Pull Type

HU	32	0	- F -	24 V DC	100 % ED	Order specifications
HU						Linear solenoid
	32					Sizes
						Design type
		0				Pull type solenoid
		4				Thrust type solenoid
						Coil terminals
			F			Flying leads (10 cm standard length)
			A			Push-on connector (optional)
				24		Nominal voltage (standard voltage) ¹⁾
					100 % ED	Perm. duty cycle under air cooled conditions (LK)

¹⁾ Other voltages are available on request up to 230 V DC

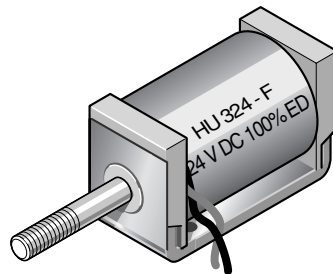

Weight:
 Complete solenoid: appr. 55 g
 Armature: appr. 11 g
 Standard:
 Voltage: 24 V DC
 Flying leads: 10 cm
 Insulation class: E (max. permissible temperature = 120 °C)

Long life expectancy through plastic bobbin armature bearing

	100	40	25	15	5	% Perm. duty cycle (ED) ²⁾
	4,2	10	16	25	64	W Nominal coil power P _N
	17				6	ms Actuation time (ED)

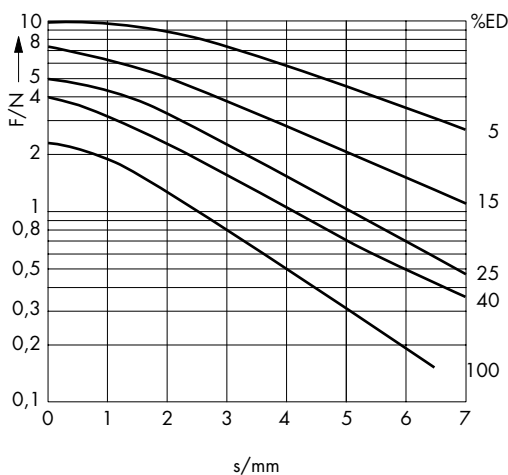

Force vs. Stroke diagram $F = f(s)$

Force measured when operating in horizontal position, at 90 % rated voltage and with winding at operating temperature

stroke $s = 0$ corresponds to armature in fully home position

²⁾ If solenoid is mounted directly onto a flat metal surface of at least 100 cm², the duty cycle can be extended up to 1.3 x nominal rating

Impulse Automation Limited
United Kingdom
Company Registration 665193

Information shown in these data sheets are for guidance purposes only, no liability is accepted for any errors or omissions. The designer or user is solely responsible for the safe and proper use of these parts, assemblies or equipment described.

HU32 Series Linear Solenoid Push or Pull Type

Series HU 320 pull type solenoid

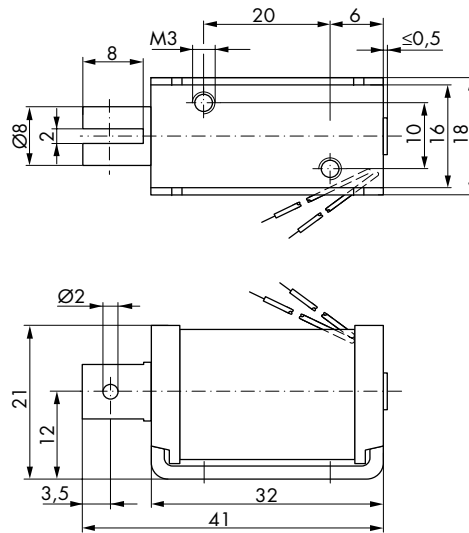

Dimensions given with armature
 in fully home position
 →
 Direction of stroke

Series HU 324 thrust type solenoid

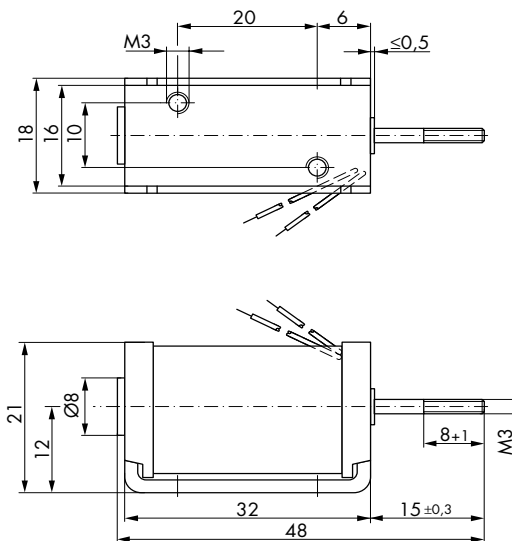

Dimensions given with armature
 in fully home position
 →
 Direction of stroke

Impulse Automation Limited
United Kingdom
Company Registration 665193

Information shown in these data sheets are for guidance purposes only, no liability is accepted for any errors or omissions. The designer or user is solely responsible for the safe and proper use of these parts, assemblies or equipment described.