

# ISO 2 Air Pilot Operated Pneumatic Valves

## 5/2 Way Single Pilot Control Valve

### Technical information

<b>Pressure range:</b>	2.5-10 bar
<b>Control pressure:</b>	2.5-10 bar (port 14 ≥ port 1 pressure)
<b>Temperature range:</b>	-15°C...+50°C
<b>Housing:</b>	Die-cast and lacquered aluminium alloy
<b>Seals:</b>	NBR
<b>Lubricant:</b>	Not required.
<b>Operating medium:</b>	5 micron filtered, lubricated or non-lubricated compressed air.



### Other information

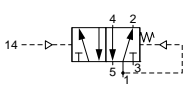

For ATEX certification use suffix code "EX" for example 76.XXX.XX.XX.EX  
Subplates are available for this product, see data sheets M1004 & M1005.

Symbol	Description	Type	Orifice	Order code
	5/2 way spring return	Poppet	8mm	<b>76.097.71.41</b>
	5/2 way spring return	Spool	8mm	<b>76.093.71.41</b>

### Dimensional drawings

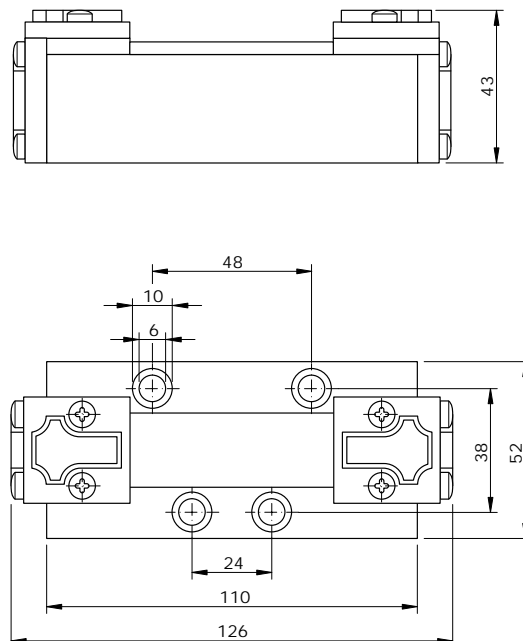

Flow rate orifice poppet type

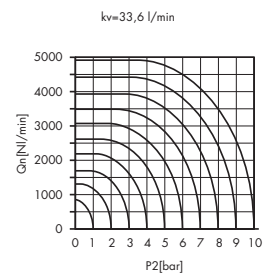

Flow rate orifice spool type

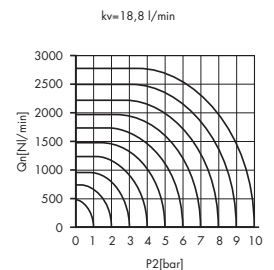

**Impulse Automation Limited**  
**United Kingdom**  
**Company Registration 665193**