

ISO 2 Solenoid Operated Pneumatic Valves

5/2 Way Single Solenoid Control Valve - Cnomo Coil

Technical information

Pressure range:	2.5-10 bar
Temperature range:	-15°C...+50°C
Housing:	Die-cast and lacquered aluminium alloy
Seals:	NBR
Lubricant:	Not required.
Earthing contact:	Part of the standard device.
Operating medium:	5 micron filtered, lubricated or non-lubricated compressed air.



Other information

 For ATEX certification use suffix code "EX" for example 76.XXX.XX.XX.EX
 Subplates are available for this product, see data sheets M1004 & M1005.
 Order coils & connecting plugs separately, see data sheet M1003.

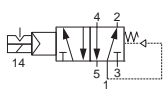
Symbol	Description	Type	Orifice	Order code
	5/2 way spring return	Poppet	8mm	76.097.97.00
	5/2 way spring return	Spool	8mm	76.093.97.00

Dimensional drawings

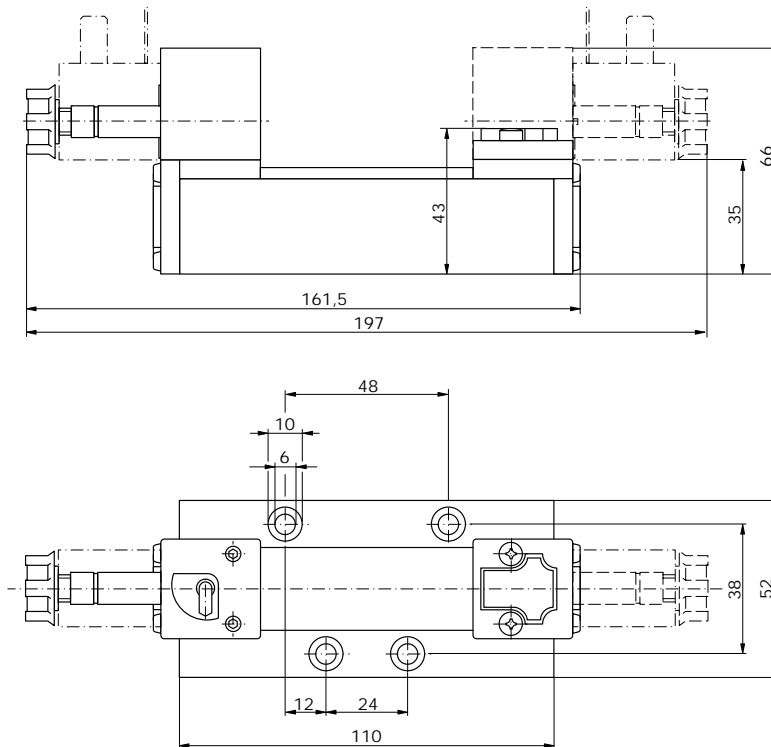

Flow rate orifice poppet type

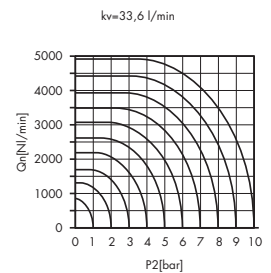

Flow rate orifice spool type

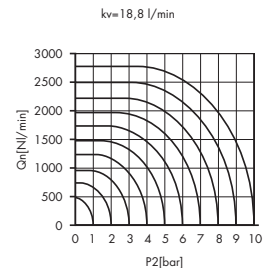

Impulse Automation Limited
United Kingdom
Company Registration 665193