

Manually Operated Pneumatic Key Valves

Key Operated Pneumatic Valve - Air Pilot Assisted

Technical information

Pressure range: 2.5-10 bar - air pilot assisted for lighter operation
Temperature range: -15°C...+50°C
Housing: Die-cast and lacquered zinc alloy
Seals: NBR
Lubricant: Not required
Operating medium: 5 micron filtered, lubricated or non-lubricated compressed air

Other information

 For ATEX certification use suffix code "EX" for example 76.XXX.XX.XX.EX
 For NPT ports use prefix code "75" for example 75.XXX.XX.XX

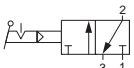
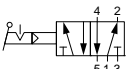

Symbol	Description	Type	Orifice	Ports	Order code
	3/2 way maintained position. Includes 2 keys.	Spool	6mm	G1/8	76.022.58.21
The key is retractable in one position only. Spare keys are not available. Keys are universal and not unique to each valve.					
	5/2 way maintained position. Includes 2 keys.	Spool	6mm	G1/8	76.023.58.41

Dimensional drawings

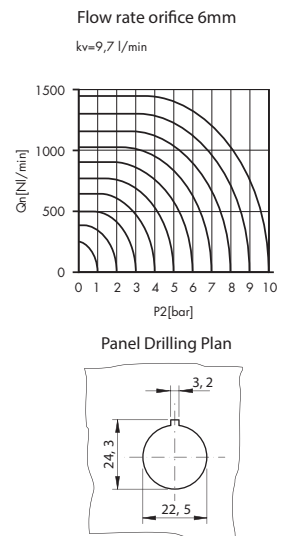
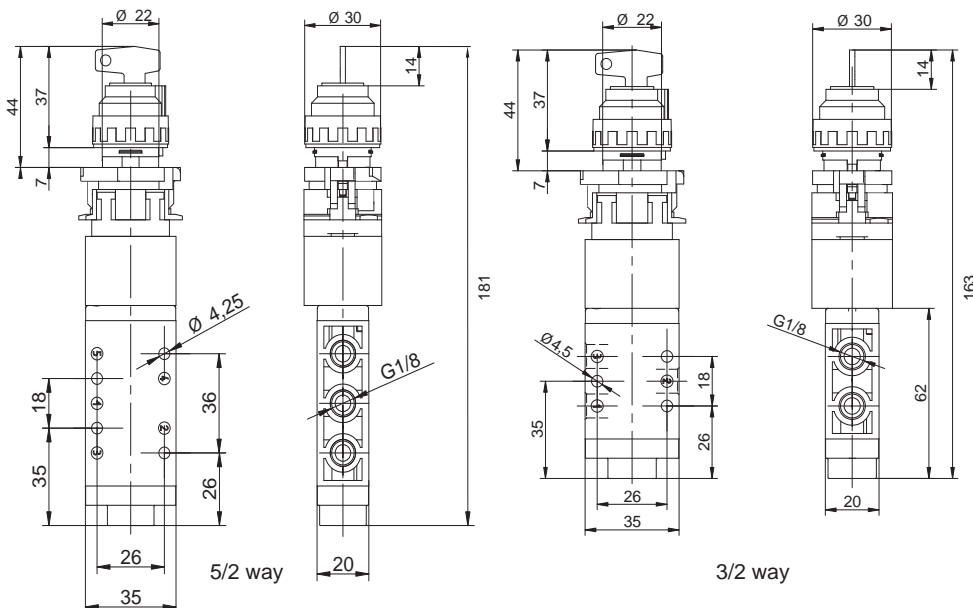

Impulse Automation Limited
United Kingdom
Company Registration 665193