

Manually Operated Pneumatic Valves

Pneumatic Selector Valve - Long Rotary Selector

Technical information

Air Pilot Assisted

Pressure range: 2.5-10 bar - air pilot assisted for lighter operation
Temperature range: -15°C...+50°C
Housing: Die-cast and lacquered zinc alloy
Seals: NBR
Lubricant: Not required
Operating medium: 5 micron filtered, lubricated or non-lubricated compressed air



Other information

 For ATEX certification use suffix code "EX" for example 76.XXX.XX.XX.EX
 For NPT ports use prefix code "75" for example 75.XXX.XX.XX

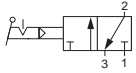
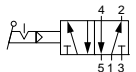
Symbol	Description	Type	Orifice	Ports	Switch	Order code
	3/2 way maintained position	Spool	6mm	G1/8	Black	76.022.57.21
	5/2 way maintained position	Spool	6mm	G1/8	Black	76.023.57.41

Dimensional drawings

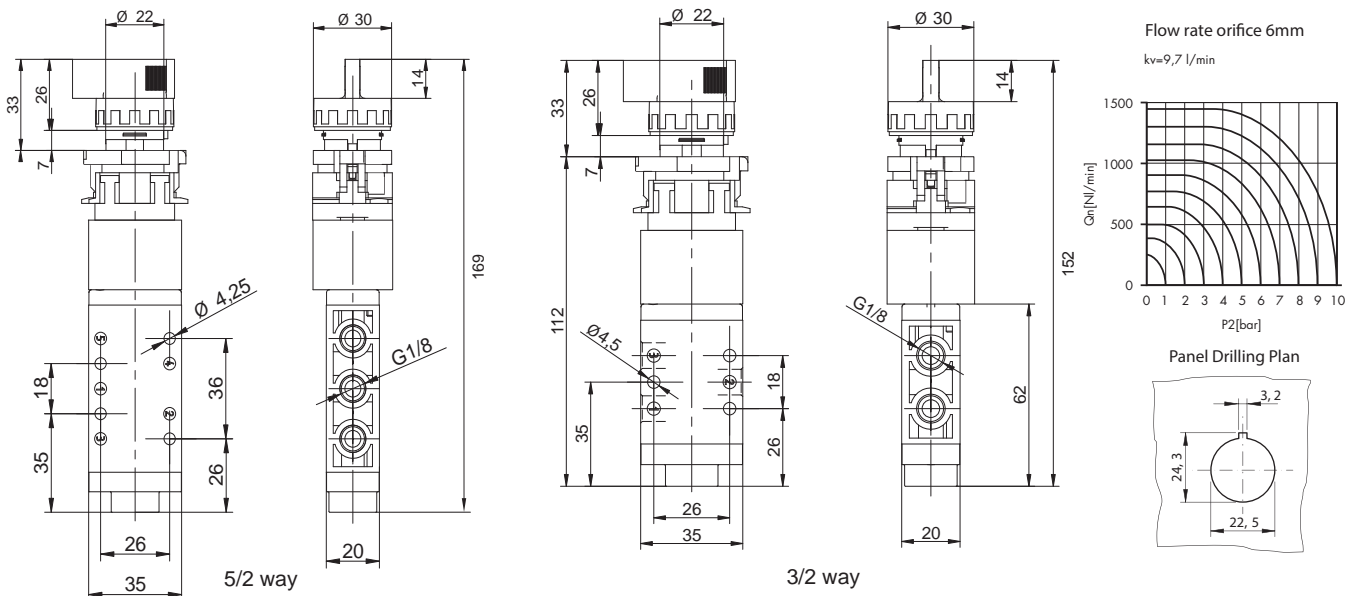

Impulse Automation Limited
United Kingdom
Company Registration 665193