

Kuhnke Pressure or Vacuum Switch

Adjustable High Sensitivity Pressure Wave Switch

Technical information

Pressure range: 3-30 mbar vacuum or pressure.
Max pressure: 100 mbar
Temperature range: -15°C...+70°C
Contact material: Ag - hard silver
Contact rating: Max, 1 Amp/220V AC
Switching rate: Max. 25Hz
Hysteresis: 0.5 mbar if free from vibration.

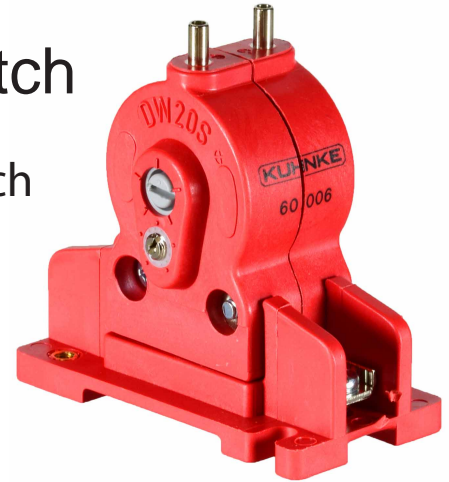

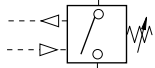
Symbol	Description	Switching range	Connection	Order code
	Pressure wave switch (DW20S) normally open	3 - 30 mbar	Tube with 3mm id	60.006

Dimensional drawings

Response Sensitivity of the Pressure Level Switch

Temperature compensation of the switch is given by the adjusting screw. The highest sensitivity of the switch is obtained when the adjusting screw is fully in. However, this results in temperature imbalance. The fully out position of the adjusting screw guarantees pressure and temperature balance, but with reduced sensitivity. With an operational setting of 0.2 mm temperature fluctuations of 30°C/20 min. are accommodated.

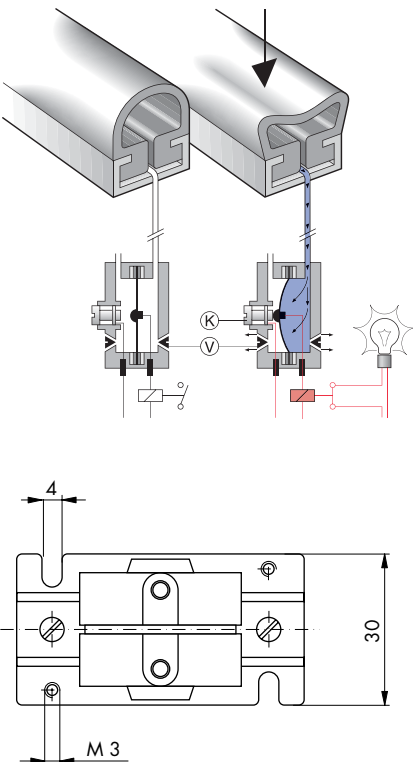

Function

Impact generates pressure within a rubber profiled tube; this signal is transferred via pneumatic tubing to the pressure wave switch. The internal diaphragm deflects, and the electrical contacts close. By adjusting the contact screw (K) and valve screw (V), the sensitivity of the switch can be altered.

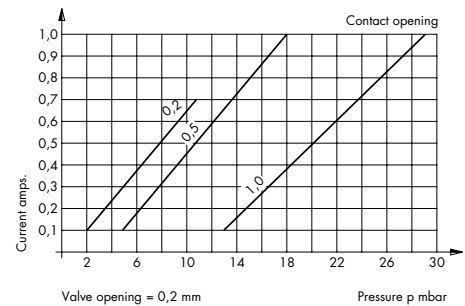
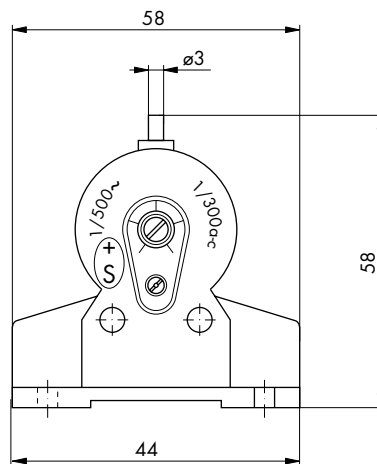

Permissible Contact Load

As long as no extremes of ambient temperature are encountered the minimum static pressure in mbar can be determined on the basis of optimum contact opening and current consumption of the connected component.

The diagram below indicates a setting of 0.2 mm for the valve needle.

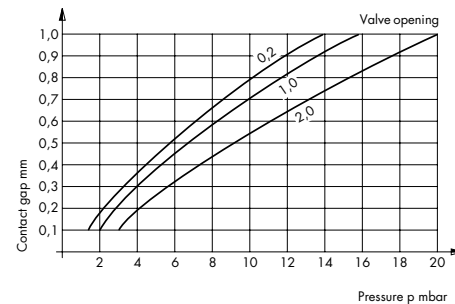

Impulse Automation Limited
United Kingdom
Company Registration 665193