

# Manually Operated Pneumatic Valves

## Pneumatic Push Button Valve - Mushroom Type Button



### Technical information

<b>Pressure range:</b>	0-10 bar
<b>Temperature range:</b>	-15°C...+50°C
<b>Housing:</b>	Die-cast and lacquered zinc alloy
<b>Seals:</b>	NBR
<b>Lubricant:</b>	Not required
<b>Operating medium:</b>	5 micron filtered, lubricated or non-lubricated compressed air

### Other information

 For ATEX certification use suffix code "EX" for example 76.XXX.XX.XX.EX  
 For NPT ports use prefix code "75" for example 75.XXX.XX.XX

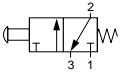
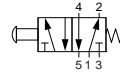
Symbol	Description	Type	Orifice	Ports	Button	Order code
	3/2 way spring return normally closed	Spool	6mm	G1/8	Red	<b>76.022.43.21</b>
	5/2 way spring return	Spool	6mm	G1/8	Red	<b>76.023.43.41</b>

### Dimensional drawings

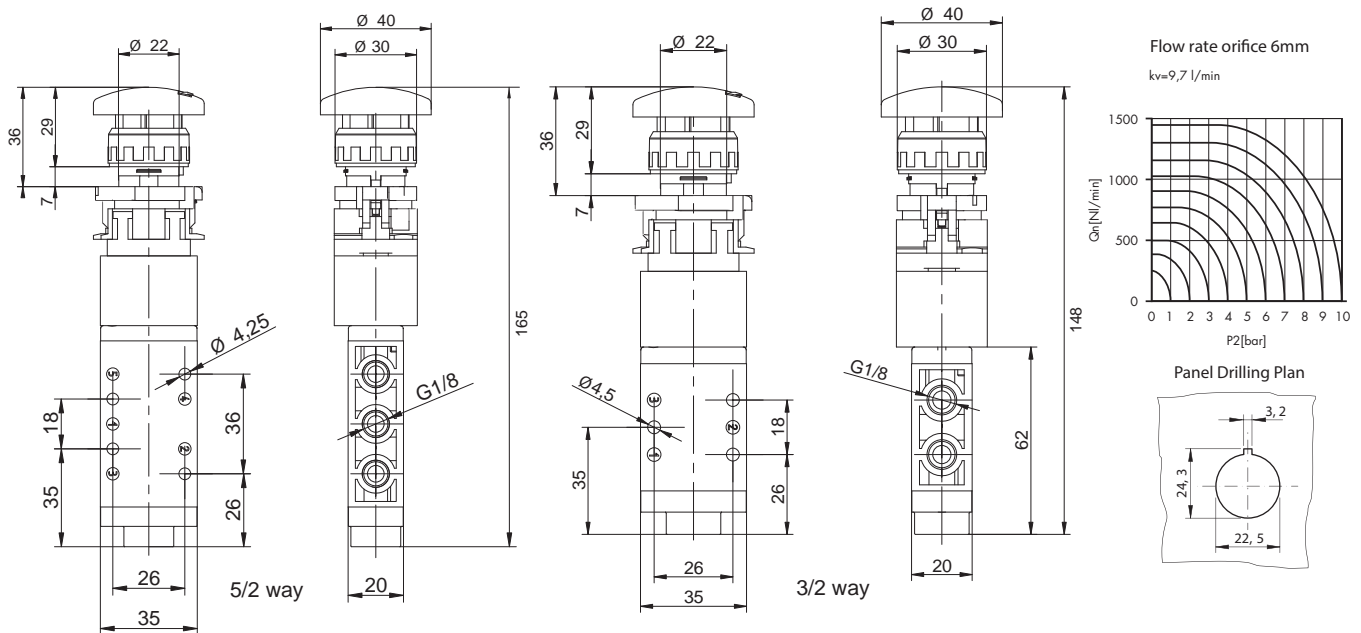

**Impulse Automation Limited**  
 United Kingdom  
 Company Registration 665193