

Manually Operated Pneumatic Valves

Pneumatic Push Button Valve - Punch Type Button

Technical information

Pressure range: 0-10 bar
Temperature range: -15°C...+50°C
Housing: Die-cast and lacquered zinc alloy
Seals: NBR
Lubricant: Not required
Operating medium: 5 micron filtered, lubricated or non-lubricated compressed air

Other information

For ATEX certification use suffix code "EX" for example 76.XXX.XX.XX.EX
 For NPT ports use prefix code "75" for example 75.XXX.XX.XX



Symbol	Description	Type	Orifice	Ports	Button	Order code
	3/2 way maintained position push to latch twist to unlatch	Spool	6mm	G1/8	Red	76.022.44.21
	5/2 way maintained position push to latch twist to unlatch	Spool	6mm	G1/8	Red	76.023.44.41

Dimensional drawings

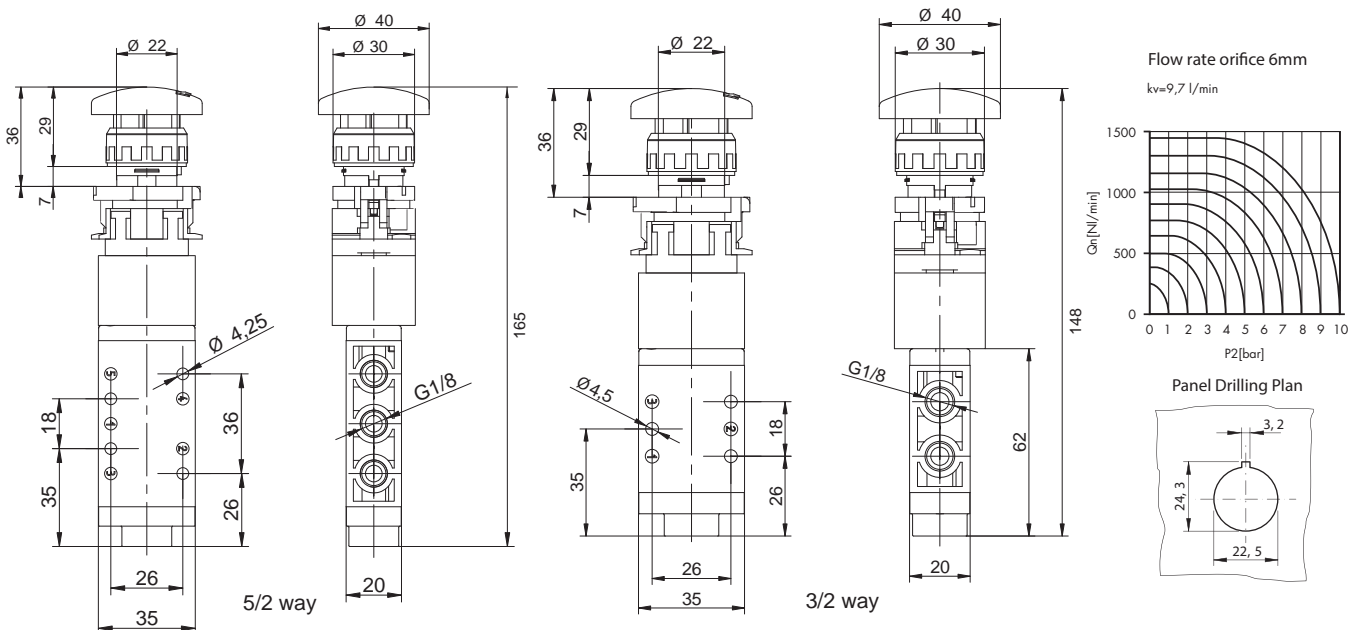

Impulse Automation Limited
 United Kingdom
 Company Registration 665193