

# Mechanically Operated Pneumatic Valves

## 3/2 Way Roller Lever Valve - Two Way Roller Function

### Technical information

<b>Pressure range:</b>	0-10 bar
<b>Temperature range:</b>	-15°C...+50°C
<b>Housing:</b>	Die-cast and lacquered zinc alloy
<b>Seals:</b>	NBR
<b>Lubricant:</b>	Not required
<b>Operating medium:</b>	5 micron filtered, lubricated or non-lubricated compressed air



### Other information

**Ex** For ATEX certification use suffix code "EX" for example 76.XXX.XX.XX.EX  
 For NPT ports use prefix code "75" for example 75.XXX.XX.XX

Symbol	Description	Type	Orifice	Ports	Order code
	3/2 way spring return normally closed	Spool	6mm	G1/8	<b>76.022.23.21</b>
	3/2 way maintained position with pilot return **	Spool	6mm	G1/8	<b>76.022.23.22</b>
	3/2 way with roller on both ends	Spool	6mm	G1/8	<b>76.022.23.10</b>

### Dimensional drawings \*\*Dimensional drawing upon request

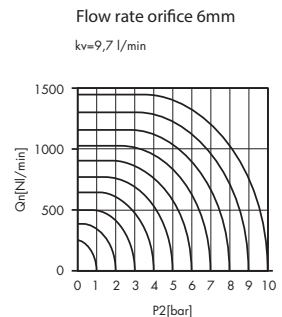
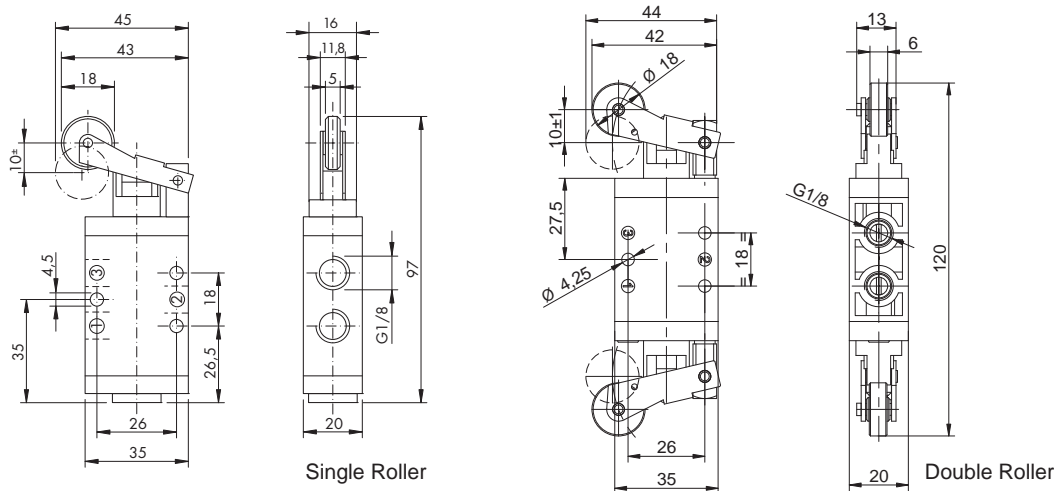

**Impulse Automation Limited**  
 United Kingdom  
 Company Registration 665193