

# Cleanline Cylinder Mountings

## Clevis

Code	Ø	M	B	C	D	E	F	G	H
18.008.01	32	M10x1.25	10	10	20	12	40	20	26
18.008.02	40	M12x1.25	12	12	24	14	48	24	32
18.008.03	50	M16x1.5	16	16	32	19	64	32	40
18.008.03	63	M16x1.5	16	16	32	19	64	32	40
18.008.04	80	M20x1.5	20	20	40	25	80	40	48
18.008.04	100	M20x1.5	20	20	40	25	80	40	48

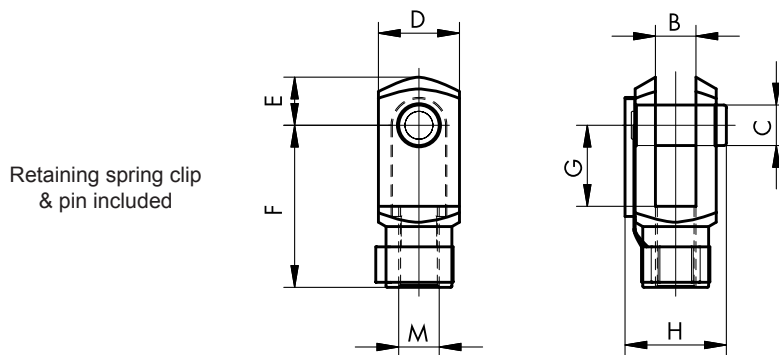

## Spherical Rod End

Code	Ø	A	B	C	d <sup>H7</sup>	E	F	G	H	SW
18.009.01	32	M10x1.25	14	20	10	28	19	57	43	17
18.009.02	40	M12x1.25	16	22	12	32	22	66	50	19
18.009.03	50	M16x1.5	21	28	16	42	27	85	64	22
18.009.03	63	M16x1.5	21	28	16	42	27	85	64	22
18.009.04	80	M20x1.5	25	33	20	50	34	102	77	30
18.009.04	100	M20x1.5	25	33	20	50	34	102	77	30

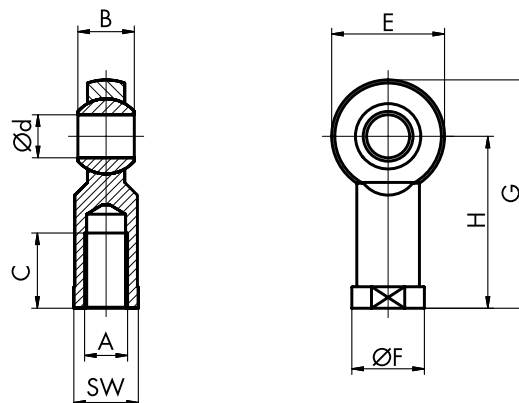

**Impulse Automation Limited**  
**United Kingdom**  
**Company Registration 665193**