

Pneumatic Air Preparation

Pressure Regulator G1/4 & G3/8 Ports

Technical information

Max. pressure: 12.5 bar
Regulation Range: 0 to 8 bar
Temperature range: 5 to 55°C
Flow rate (P = 6.3 bar): G1/4 ports 850 NI/min / G3/8 ports 1500 NI/min
Material: Polyamide



| Description | Ports | Order code |
|-------------------------------|-------|------------|
| Pressure regulator G1/4 ports | G1/4 | R4ST |
| Pressure regulator G3/8 ports | G3/8 | R3ST |

Dimensional drawings

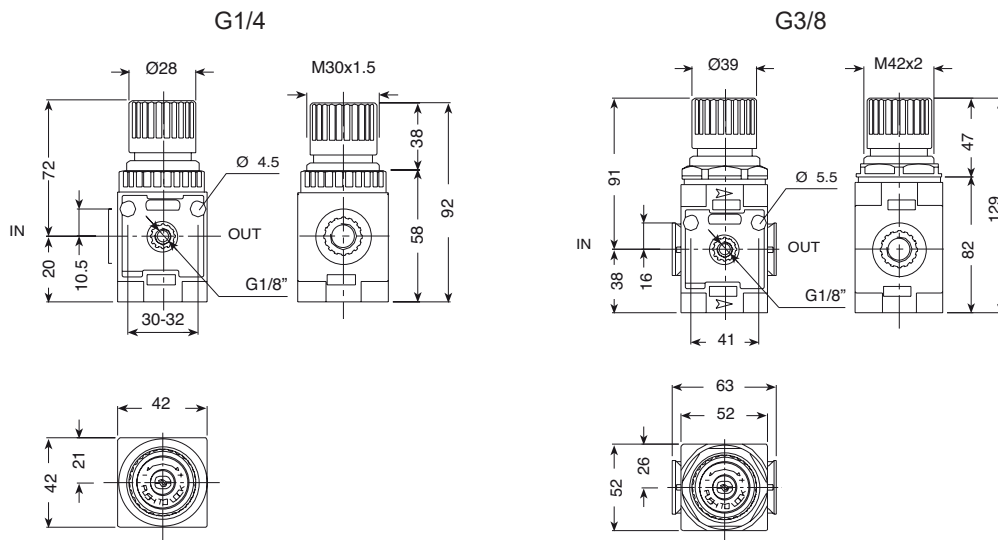

Mounting Bracket (G1/4)

Order code: **SQP**

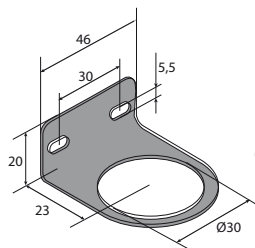

Mounting Bracket (G3/8)

Order code: **SQM**

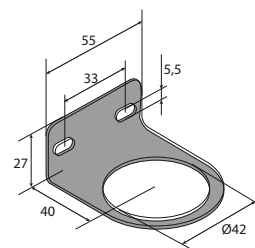

0 to 12 Bar Pressure Gauge

40mm Ø Order code: **M4P812W**
 50mm Ø Order code: **M5P812W**

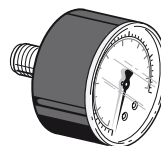

Impulse Automation Limited
United Kingdom
Company Registration 665193