

# Profile Cylinder Mountings

## Clevis

Code	∅	M	B	C	D	E	F	G	H
18.008.05	125	M27x2	30	30	55	38	110	54	65
18.008.06	160	M36x2	35	35	70	44	144	72	84
	200								

Pin and circlips included.

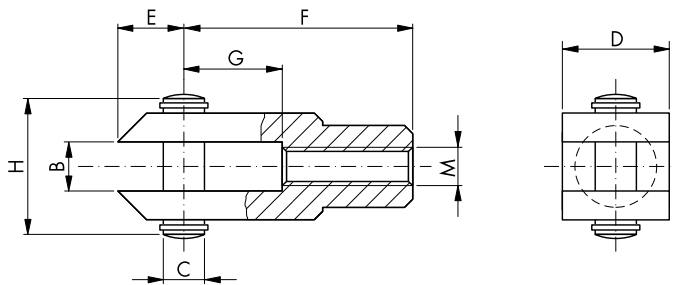

## Spherical Rod End

Code	∅	A	∅d	B	E	F	H	G	C	SW
18.009.05	125	M27x2	30	37	70	50	110	145	51	41
18.009.06	160	M36x2	35	43	80	58	125	165	56	50
	200									

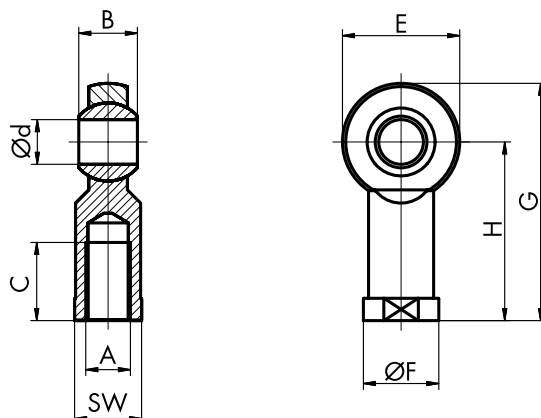

**Impulse Automation Limited**  
**United Kingdom**  
**Company Registration 665193**